

Description

IS31FL3218 is comprised of 18 constant current channels each with independent PWM control, designed for driving LEDs. The output current of each channel can be set at up to 23mA (Max.) by an external resistor. The average LED current of each channel can be changed in 256 steps by changing the PWM duty cycle through an I2C interface.

Features

- Supply voltage range from 2.7V to 5.5V
- I2C interface, automatic address increment function
- Internal reset register
- Modulate LED brightness with 256 steps PWM
- Each channel can be controlled independently
- SOP-24 package

Quick Start

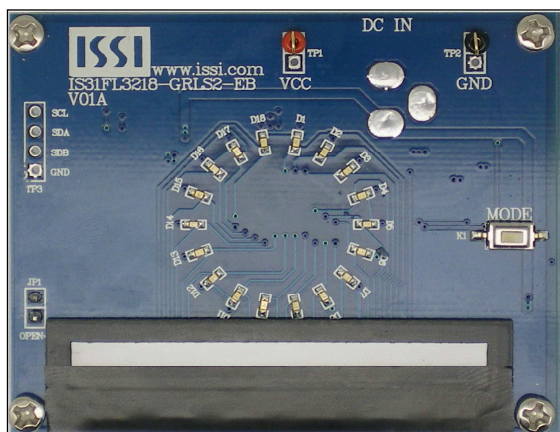

Figure 1: Photo of IS31FL3218 Evaluation Board

Recommended Equipment

- 5.0V, 2A power supply

Absolute Maximum Ratings

- $\leq 5.5V$ power supply

Caution: Do not exceed the above condition, otherwise the board will be damaged.

Procedure

The IS31FL3218 evaluation board is fully assembled and tested. Follow the steps below to verify the board.

Caution: Do not turn on the power supply until all connections are completed.

- 1) Connect the ground terminal of the power supply to the GND and the positive terminal to the VCC. Or connect the DC power to the connector (DC IN).
- 2) Turn on the power supply and pay attention to the supply current. If the current exceeds 600mA, please check for circuit fault.
- 3) Enter the desired mode of display by toggling the MODE button.

Evaluation Board Ordering Information

Part No.	IC Package
IS31FL3218-GRLS2-EB	SOP-24, Lead-free

Table1: Ordering Information

For pricing, delivery, and ordering information, please contact ISSI's analog marketing at analog_mkt@issi.com or (408) 969-6600.

Evaluation Board Operation

The IS31FL3218 evaluation board has eight display modes. Press MODE button to switch configurations.

- 1) (Default mode) The two groups of Blue LED (6 pcs each) chasing each other with a tailing visual effect.
- 2) The two groups of Blue LED (9 pcs each) chasing each other with a tailing visual effect.
- 3) 9 Blue LEDs cycle round with increasing circling speed.
- 4) Blue LED in three groups (3 pcs in one group) chasing each other.
- 5) 18 Blue LEDs breath together.
- 6) 6 pcs of RGB LEDs to form a light bar. Color changes from left to right.
- 7) RGB light bar with mixed color moves from left to right.
- 8) RGB light bar changes color from two sides to the middle and then from middle to two sides.

***Note:**

IS31FL3218 solely controls the FxLED function on the evaluation board.

Software Control

JP1 default setting is close circuit. If it is set to open, the on-board MCU will stop working. The I2C pins are set to High Impedance. External I2C signals can be connected to TP3 to control the IS31FL3218 LED driver.

Please refer to the datasheet for how to control the IS31FL3218.

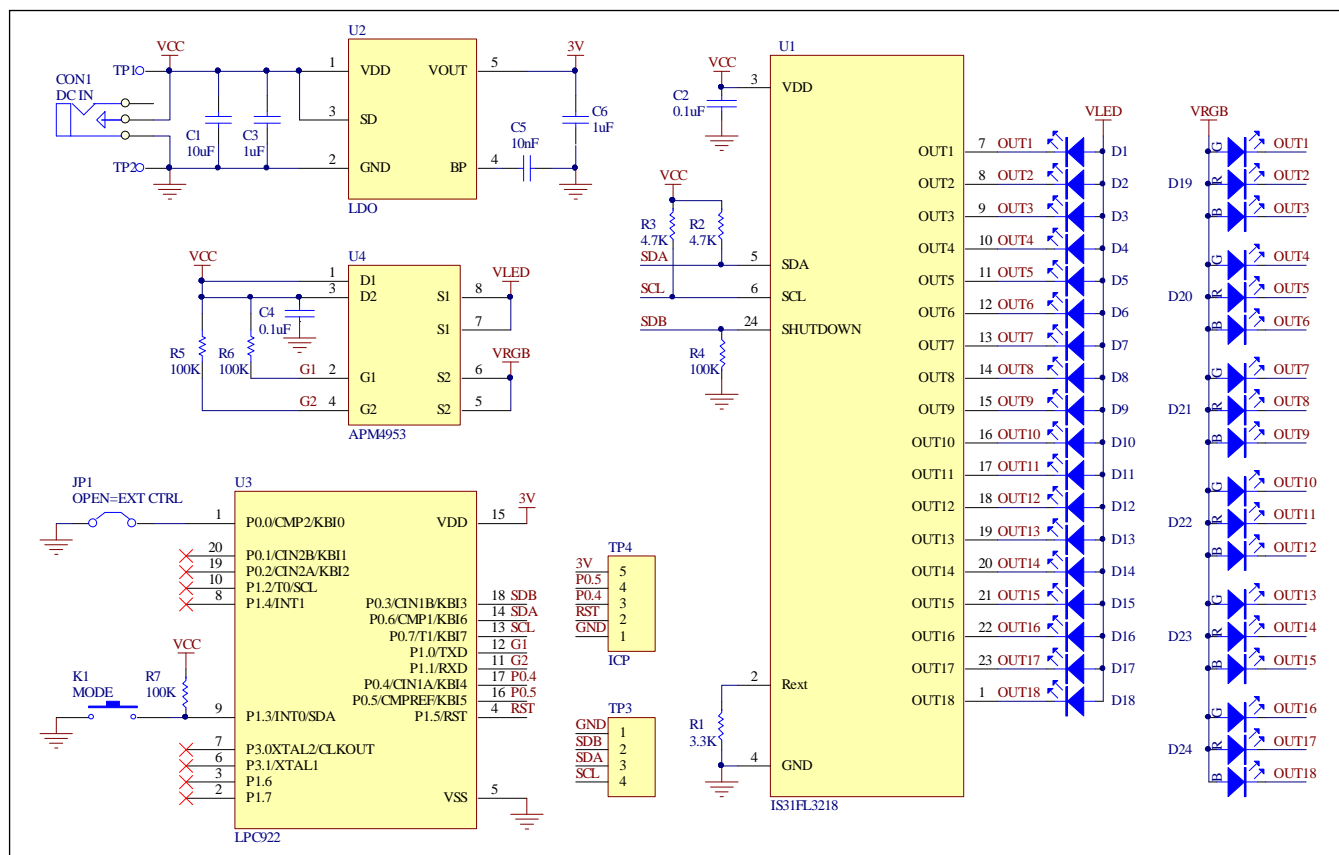

Figure 2: IS31FL3218 Application Schematic

Bill of Materials

Name	Symbol	Description	Qty	Supplier	Part No.
LED Driver	U1	18CH LED Driver	1	ISSI	IS31FL3218
LDO	U2	Low-dropout Regulator	1	PAM	PAM3101
MCU	U3	Microcontroller	1	NXP	LPC922
PMOS	U4	Dual PMOS	1	ANPEC	APM4953
Diodes	D1~D18	Diode, LED Blue, SMD	18	Everlight	19-217/BHC-ZL 1M2RY/3T
Diodes	D19~D24	Diode, LED RGB, SMD	6	Everlight	99-235/RGBC/T R8
Resistor	R1	RES,3.3k,1/16W,±5%,SMD	1		
Resistors	R2~R3	RES,4.7k,1/16W,±5%,SMD	2		
Resistors	R4~R7	RES,100k,1/16W,±5%,SMD	4		
Capacitor	C1	CAP,10µF,16V,±20%,SMD	1		
Capacitor	C2,C4	CAP, 0.1µF,16V,±20%,SMD	2		
Capacitors	C3,C6	CAP,1µF,16V,±20%,SMD	2		
Capacitor	C5	CAP,10nF,16V,±20%,SMD	1		
Button	K1	Button SMD	1		

Table 2: Bill of Materials, refer to Figure 2 above.

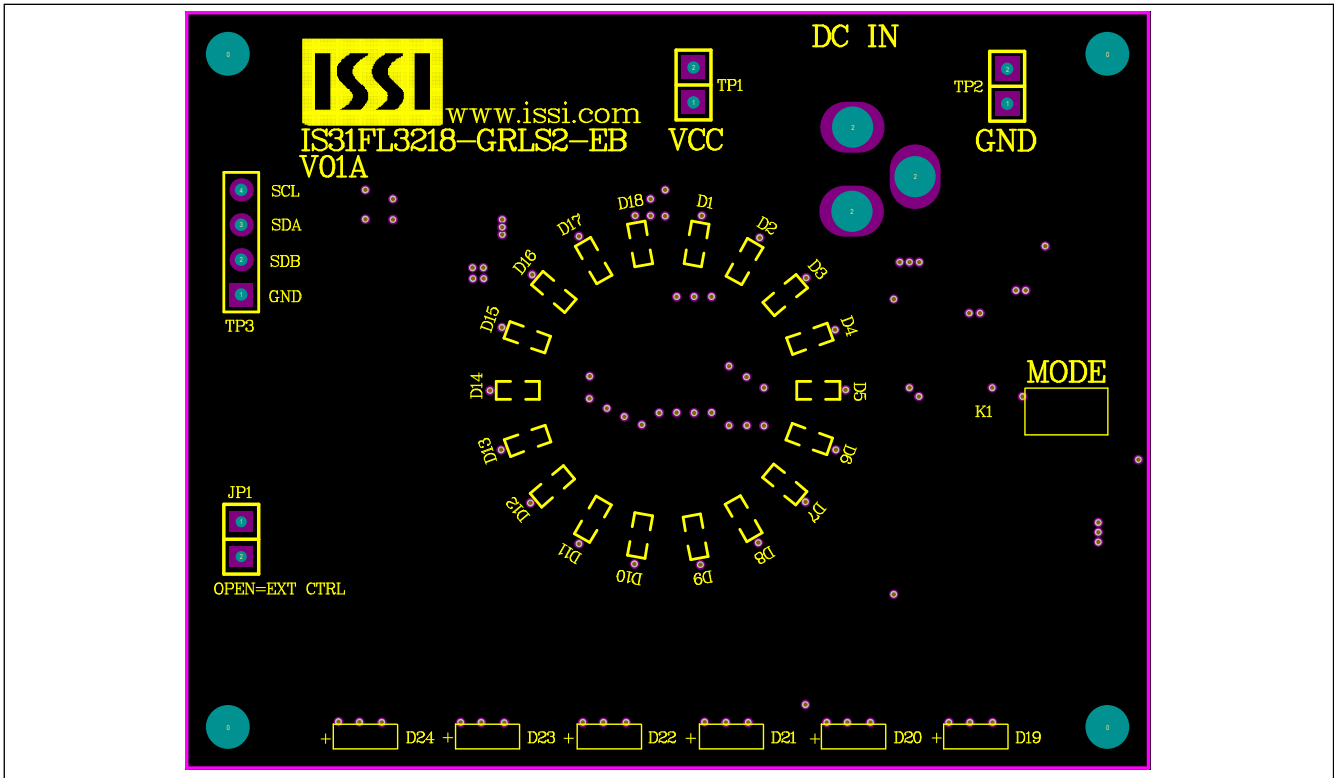

Figure 3: Board Component Placement Guide -Top Layer

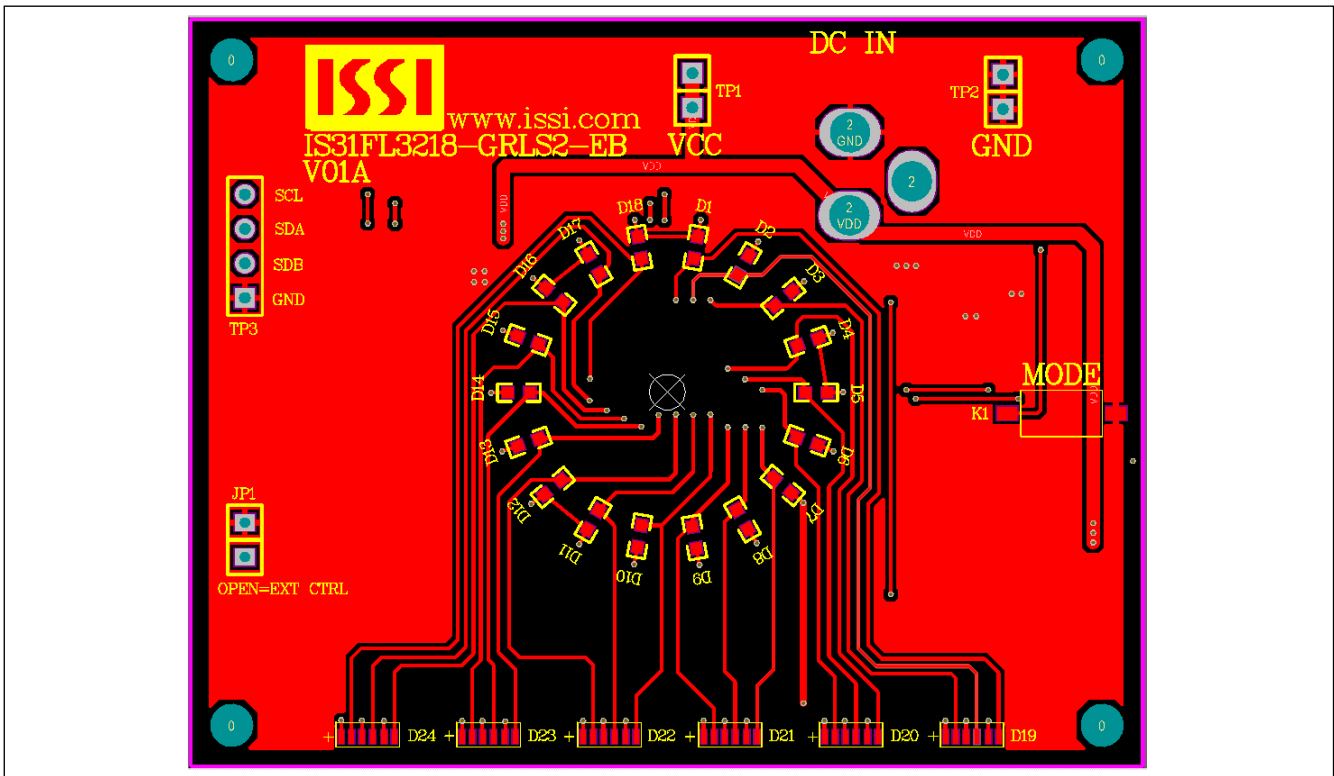

Figure 4: Board PCB Layout- Top Layer

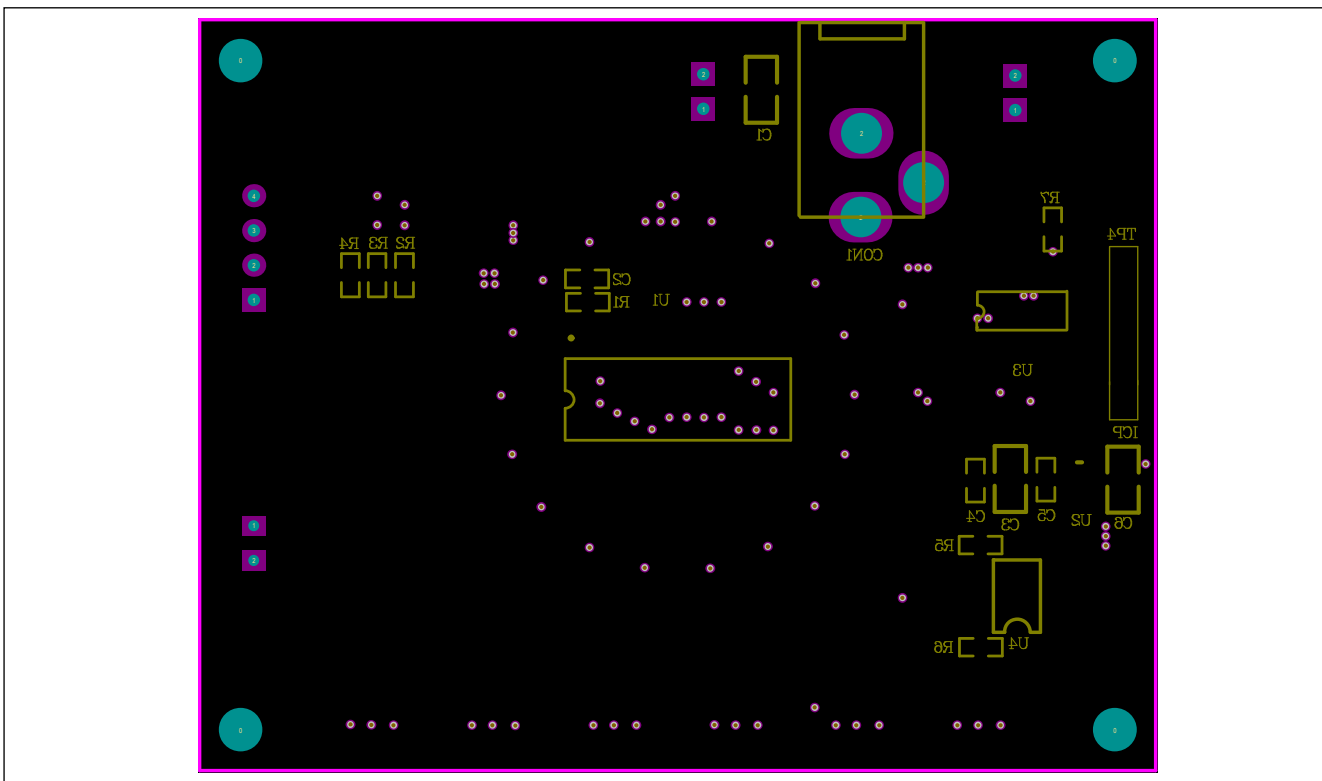

Figure 5: Board Component Placement Guide -Bottom Layer

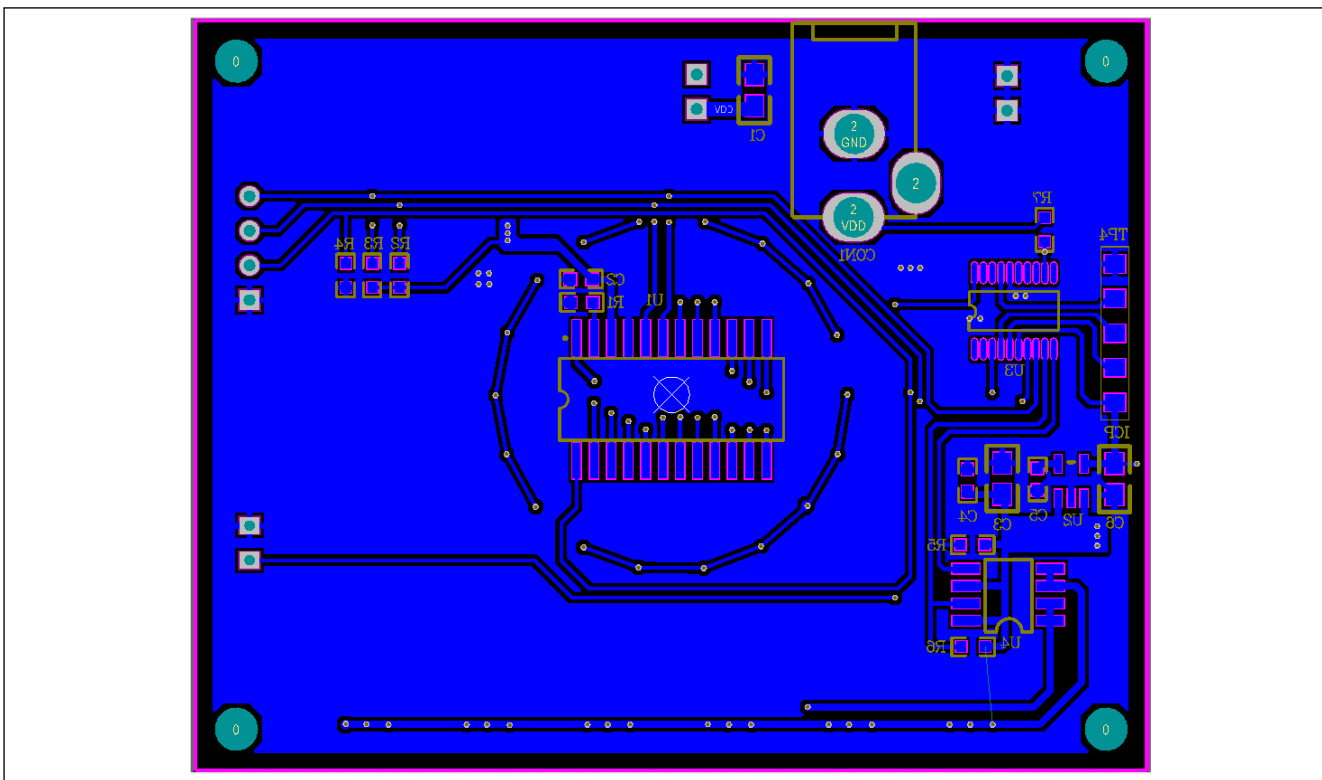

Figure 6: Board PCB Layout-Bottom Layer



IS31FL3218 18 Channels LED Driver Evaluation Board Guide

Copyright © 2012 Integrated Silicon Solution, Inc. All rights reserved. ISSI reserves the right to make changes to this specification and its products at any time without notice. ISSI assumes no liability arising out of the application or use of any information, products or services described herein. Customers are advised to obtain the latest version of this device specification before relying on any published information and before placing orders for products.

Integrated Silicon Solution, Inc. does not recommend the use of any of its products in life support applications where the failure or malfunction of the product can reasonably be expected to cause failure of the life support system or to significantly affect its safety or effectiveness. Products are not authorized for use in such applications unless Integrated Silicon Solution, Inc. receives written assurance to its satisfaction, that:

- a.) the risk of injury or damage has been minimized;
- b.) the user assume all such risks; and
- c.) potential liability of Integrated Silicon Solution, Inc is adequately protected under the circumstances