

IS61DDP2B41M18A/A1/A2 IS61DDP2B451236A/A1/A2



1Mx18, 512Kx36

18Mb DDR-IIP(Burst 4) CIO SYNCHRONOUS SRAM

(2.0 Cycle Read Latency)

ADVANCED INFORMATION
DECEMBER 2011

FEATURES

- 512Kx36 and 1Mx18 configuration available.
- On-chip Delay-Locked Loop (DLL) for wide data valid window.
- Common I/O read and write ports.
- Synchronous pipeline read with self-timed late write operation.
- Double Data Rate (DDR) interface for read and write input ports.
- 2.0 cycle read latency.
- Fixed 4-bit burst for read and write operations.
- Clock stop support.
- Two input clocks (K and K#) for address and control registering at rising edges only.
- Two echo clocks (CQ and CQ#) that are delivered simultaneously with data.
- +1.8V core power supply and 1.5V to 1.8V VDDQ, used with 0.75 to 0.9V VREF.
- HSTL input and output interface.
- Registered addresses, write and read controls, byte writes, data in, and data outputs.
- Full data coherency.
- Boundary scan using limited set of JTAG 1149.1 functions.
- Byte write capability.
- Boundary scan using limited set of JTAG 1149.1 functions.
- Byte write capability.
- Fine ball grid array (FBGA) package:
 - 13mm x 15mm & 15mm x 17mm body size
 - 165-ball (11 x 15) array
- Programmable impedance output drivers via 5x user-supplied precision resistor.
- Data Valid Pin (QVLD).
- ODT (On Die Termination) feature is supported optionally on data inputs, K/K#, and BW_x#.
- The end of top mark (A/A1/A2) is to define options.
 - IS61DDP2B451236A : No ODT
 - IS61DDP2B451236A1 : Option1
 - IS61DDP2B451236A2 : Option2Refer to more detail description at page 6 for each ODT option.

DESCRIPTION

The 18Mb IS61DDP2B451236A/A1/A2 and IS61DDP2B41M18A/A1/A2 are synchronous, high-performance CMOS static random access memory (SRAM) devices. These SRAMs have a common I/O bus. The rising edge of K clock initiates the read/write operation, and all internal operations are self-timed. Refer to the *Timing Reference Diagram for Truth Table* for a description of the basic operations of these DDR-IIP (Burst of 4) CIO SRAMs. Read and write addresses are registered on alternating rising edges of the K clock. Reads and writes are performed in double data rate.

The following are registered internally on the rising edge of the K clock:

- Read/write address
- Read enable
- Write enable
- Byte writes
- Data-in for first and third burst addresses
- Data-out for first and third burst addresses

The following are registered on the rising edge of the K# clock:

- Byte writes
- Data-in for second and fourth burst addresses
- Data-out for second and fourth burst addresses

Byte writes can change with the corresponding data-in to enable or disable writes on a per-byte basis. An internal write buffer enables the data-ins to be registered one cycle after the write address. The first data-in burst is clocked one cycle later than the write command signal, and the second burst is timed to the following rising edge of the K# clock. Two full clock cycles are required to complete a write operation.

During the burst read operation, the data-outs from the first bursts are updated from output registers of the second rising edge of the K clock (starting two cycles later after read command). The data-outs from the second burst are updated with the third rising edge of the K# clock where read command receives at the first rising edge of K.

The device is operated with a single +1.8V power supply and is compatible with HSTL I/O interfaces.

Copyright © 2010 Integrated Silicon Solution, Inc. All rights reserved. ISSI reserves the right to make changes to this specification and its products at any time without notice. ISSI assumes no liability arising out of the application or use of any information, products or services described herein. Customers are advised to obtain the latest version of this device specification before relying on any published information and before placing orders for products.

Integrated Silicon Solution, Inc. does not recommend the use of any of its products in life support applications where the failure or malfunction of the product can reasonably be expected to cause failure of the life support system or to significantly affect its safety or effectiveness. Products are not authorized for use in such applications unless Integrated Silicon Solution, Inc. receives written assurance to its satisfaction, that:

- a.) the risk of injury or damage has been minimized;
- b.) the user assume all such risks; and
- c.) potential liability of Integrated Silicon Solution, Inc is adequately protected under the circumstances

IS61DDP2B41M18A/A1/A2

IS61DDP2B451236A/A1/A2



Package ballout and description

x36 FBGA Ball Configuration (Top View)

	1	2	3	4	5	6	7	8	9	10	11
A	CQ#	NC/SA ¹	NC/SA ¹	R/W#	BW ₂ #	K#	BW ₁ #	LD#	NC/SA ¹	NC/SA ¹	CQ
B	NC	DQ27	DQ18	SA	BW ₃ #	K	BW ₀ #	SA	NC	NC	DQ8
C	NC	NC	DQ28	V _{SS}	SA	NC	SA	V _{SS}	NC	DQ17	DQ7
D	NC	DQ29	DQ19	V _{SS}	V _{SS}	V _{SS}	V _{SS}	V _{SS}	NC	NC	DQ16
E	NC	NC	DQ20	V _{DDQ}	V _{SS}	V _{SS}	V _{SS}	V _{DDQ}	NC	DQ15	DQ6
F	NC	DQ30	DQ21	V _{DDQ}	V _{DD}	V _{SS}	V _{DD}	V _{DDQ}	NC	NC	DQ5
G	NC	DQ31	DQ22	V _{DDQ}	V _{DD}	V _{SS}	V _{DD}	V _{DDQ}	NC	NC	DQ14
H	D _{off} #	V _{REF}	V _{DDQ}	V _{DDQ}	V _{DD}	V _{SS}	V _{DD}	V _{DDQ}	V _{DDQ}	V _{REF}	ZQ
J	NC	NC	DQ32	V _{DDQ}	V _{DD}	V _{SS}	V _{DD}	V _{DDQ}	NC	DQ13	DQ4
K	NC	NC	DQ23	V _{DDQ}	V _{DD}	V _{SS}	V _{DD}	V _{DDQ}	NC	DQ12	DQ3
L	NC	DQ33	DQ24	V _{DDQ}	V _{SS}	V _{SS}	V _{SS}	V _{DDQ}	NC	NC	DQ2
M	NC	NC	DQ34	V _{SS}	V _{SS}	V _{SS}	V _{SS}	V _{SS}	NC	DQ11	DQ1
N	NC	DQ35	DQ25	V _{SS}	SA	SA	SA	V _{SS}	NC	NC	DQ10
P	NC	NC	DQ26	SA	SA	QVLD	SA	SA	NC	DQ9	DQ0
R	TDO	TCK	SA	SA	SA	ODT	SA	SA	SA	TMS	TDI

Notes:

- The following balls are reserved for higher densities: 9A for 36Mb, 3A for 72Mb, 10A for 144Mb, and 2A for 288Mb.

x18 FBGA Ball Configuration (Top View)

	1	2	3	4	5	6	7	8	9	10	11
A	CQ#	NC/SA ¹	NC/SA ¹	R/W#	BW ₁ #	K#	NC/SA ¹	LD#	SA	NC/SA ¹	CQ
B	NC	DQ9	NC	SA	NC/SA ¹	K	BW ₀ #	SA	NC	NC	DQ8
C	NC	NC	NC	V _{SS}	SA	NC	SA	V _{SS}	NC	DQ7	NC
D	NC	NC	DQ10	V _{SS}	V _{SS}	V _{SS}	V _{SS}	V _{SS}	NC	NC	NC
E	NC	NC	DQ11	V _{DDQ}	V _{SS}	V _{SS}	V _{SS}	V _{DDQ}	NC	NC	DQ6
F	NC	DQ12	NC	V _{DDQ}	V _{DD}	V _{SS}	V _{DD}	V _{DDQ}	NC	NC	DQ5
G	NC	NC	DQ13	V _{DDQ}	V _{DD}	V _{SS}	V _{DD}	V _{DDQ}	NC	NC	NC
H	D _{off} #	V _{REF}	V _{DDQ}	V _{DDQ}	V _{DD}	V _{SS}	V _{DD}	V _{DDQ}	V _{DDQ}	V _{REF}	ZQ
J	NC	NC	NC	V _{DDQ}	V _{DD}	V _{SS}	V _{DD}	V _{DDQ}	NC	DQ4	NC
K	NC	NC	DQ14	V _{DDQ}	V _{DD}	V _{SS}	V _{DD}	V _{DDQ}	NC	NC	DQ3
L	NC	DQ15	NC	V _{DDQ}	V _{SS}	V _{SS}	V _{SS}	V _{DDQ}	NC	NC	DQ2
M	NC	NC	NC	V _{SS}	V _{SS}	V _{SS}	V _{SS}	V _{SS}	NC	DQ1	NC
N	NC	NC	DQ16	V _{SS}	SA	SA	SA	V _{SS}	NC	NC	NC
P	NC	NC	DQ17	SA	SA	QVLD	SA	SA	NC	NC	DQ0
R	TDO	TCK	SA	SA	SA	ODT	SA	SA	SA	TMS	TDI

Notes:

- The following balls are reserved for higher densities: 3A for 36Mb, 10A for 72Mb, 2A for 144Mb, and 7A for 288Mb.

Ball Descriptions

Symbol	Type	Description
K, K#	Input	Input clock: This input clock pair registers address and control inputs on the rising edge of K, and registers data on the rising edge of K and the rising edge of K#. K# is ideally 180 degrees out of phase with K. All synchronous inputs must meet setup and hold times around the clock rising edges. These balls cannot remain VREF level.
CQ, CQ#	Output	Synchronous echo clock outputs: The edges of these outputs are tightly matched to the synchronous data outputs and can be used as a data valid indication. These signals are free running clocks and do not stop when Q tri-states.
Doff#	Input	DLL disable and reset input : When low, this input causes the DLL to be bypassed and reset the previous DLL information. When high, DLL will start operating and lock the frequency after tCK lock time. The device behaves in one read latency mode when the DLL is turned off. In this mode, the device can be operated at a frequency of up to 167 MHz.
QVLD	Output	Valid output indicator: The Q Valid indicates valid output data. QVLD is edge aligned with CQ and CQ#.
SA	Input	Synchronous address inputs: These inputs are registered and must meet the setup and hold times around the rising edge of K. These inputs are ignored when device is deselected.
DQ0 - DQn	Bidir	Data input and output signals. Input data must meet setup and hold times around the rising edges of K and K# during WRITE operations. These pins drive out the requested data when the read operation is active. Valid output data is synchronized to the respective CQ and CQ#. See BALL CONFIGURATION figures for ball site location of individual signals. The x18 device uses DQ0~DQ17. DQ18~DQ35 should be treated as NC pin. The x36 device uses DQ0~DQ35.
R/W#	Input	Synchronous Read or Write input. When LD# is low, this input designates the access type (read when it is High, write when it is Low) for loaded address. R/W# must meet the setup and hold times around edge of K.
LD#	Input	Synchronous load. This input is brought Low when a bus cycle sequence is defined. This definition includes address and read/write direction.
BW _x #	Input	Synchronous byte writes: When low, these inputs cause their respective byte to be registered and written during WRITE cycles. These signals are sampled on the same edge as the corresponding data and must meet setup and hold times around the rising edges of K and K# for each of the two rising edges comprising the WRITE cycle. See Write Truth Table for signal to data relationship.
V _{REF}	Input reference	HSTL input reference voltage: Nominally VDDQ/2, but may be adjusted to improve system noise margin. Provides a reference voltage for the HSTL input buffers.
V _{DD}	Power	Power supply: 1.8 V nominal. See DC Characteristics and Operating Conditions for range.
V _{DDQ}	Power	Power supply: Isolated output buffer supply. Nominally 1.5 V. See DC Characteristics and Operating Conditions for range.
V _{SS}	Ground	Ground of the device
ZQ	Input	Output impedance matching input: This input is used to tune the device outputs to the system data bus impedance. Q and CQ output impedance are set to 0.2xRQ, where RQ is a resistor from this ball to ground. This ball can be connected directly to VDDQ, which enables the minimum impedance mode. This ball cannot be connected directly to VSS or left unconnected. In ODT (On Die Termination) enable devices, the ODT termination values tracks the value of RQ. The ODT range is selected by ODT control input.
TMS, TDI, TCK	Input	IEEE1149.1 test inputs: 1.8 V I/O levels. These balls may be left not connected if the JTAG function is not used in the circuit.
TDO	Output	IEEE1149.1 clock input: 1.8 V I/O levels. This ball must be tied to VSS if the JTAG function is not used in the circuit.
NC	N/A	No connect: These signals should be left floating or connected to ground to improve package heat dissipation.
ODT	Input	ODT control; Refer to SRAM features for the details.

SRAM Features Description

Block Diagram

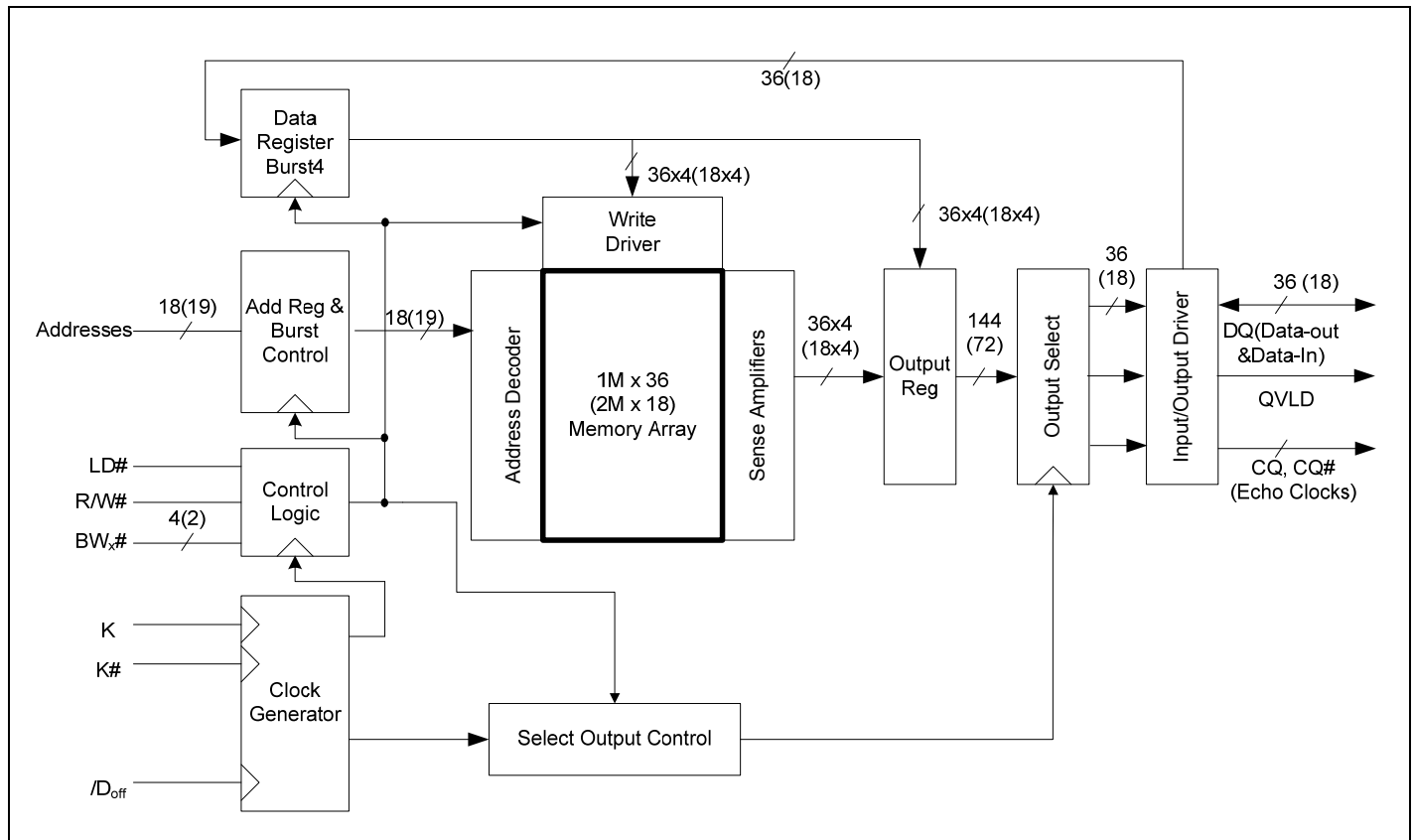

Note: Numerical values in parentheses refer to the x18 device configuration.

Read Operations

The SRAM operates continuously in a burst-of-four mode. Read cycles are started by registering R/W# in active high state at the rising edge of the K clock. K and K#, are also used to control the timing to the outputs. The data corresponding to the first address is clocked two cycles later by the rising edge of the K clock. The data corresponding to the second burst is clocked two and half cycles later by the following rising edge of the K# clock. A set of free-running echo clocks, CQ and CQ#, are produced internally with timings identical to the data-outs. The echo clocks can be used as data capture clocks by the receiver device.

Whenever LD# is low, a new address is registered at the rising edge of the K clock. A NOP operation (LD# is high) does not terminate the previous read. The output drivers disable automatically to a high-Z state.

Write Operations

Write operations can also be initiated at every other rising edge of the K clock whenever R/W# is low. The write address is also registered at that time. When the address needs to change, LD# needs to be low simultaneously to be registered by the rising edge of K. Again, the write always occurs in bursts of four.

Because of its common I/O architecture, the data bus must be tri-stated at least one cycle before the new data-in is presented at the DQ bus.

IS61DDP2B41M18A/A1/A2

IS61DDP2B451236A/A1/A2



The write data is provided in a 'late write' mode; that is, the data-in corresponding to the first address of the burst, is presented one cycle later or at the rising edge of the following K clock. The data-in corresponding to the second write burst address follows next, registered by the rising edge of K#.

The data-in provided for writing is initially kept in write buffers. The information on these buffers is written into the array on the third write cycle. A read cycle to the last two write address produces data from the write buffers. Similarly, a read address followed by the same write address produces the latest write data. The SRAM maintains data coherency.

During a write, the byte writes independently control which byte of any of the two burst addresses is written. (See *X18/X36 Write Truth Tables* and *Timing Reference Diagram for Truth Table*)

Whenever a write is disabled (R/W# is high at the rising edge of K), data is not written into the memory.

RQ Programmable Impedance

An external resistor, RQ, must be connected between the ZQ pin on the SRAM and V_{SS} to enable the SRAM to adjust its output driver impedance. The value of RQ must be 5x the value of the intended line impedance driven by the SRAM. For example, an RQ of 250Ω results in a driver impedance of 50Ω. The allowable range of RQ to guarantee impedance matching is between 175Ω and 350Ω at V_{DDQ}=1.5V. The RQ resistor should be placed less than two inches away from the ZQ ball on the SRAM module. The capacitance of the loaded ZQ trace must be less than 7.5pF.

The ZQ pin can also be directly connected to V_{DDQ} to obtain a minimum impedance setting. ZQ should not be connected to V_{SS}.

Programmable Impedance and Power-Up Requirements

Periodic readjustment of the output driver impedance is necessary as the impedance is greatly affected by drifts in supply voltage and temperature. During power-up, the driver impedance is in the middle of allowable impedances values. The final impedance value is achieved within 1024clock cycles.

Valid Data Indicator (QVLD)

A data valid pin (QVLD) is available to assist in high-speed data output capture. This output signal is edge-aligned with the echo clock and is asserted HIGH half a cycle before valid read data is available and asserted LOW half a cycle before the final valid read data arrives.

Delay Locked Loop (DLL)

Delay Locked Loop (DLL) is a new system to align the output data coincident with clock rising or falling edge to enhance the output valid timing characteristics. It is locked to the clock frequency and is constantly adjusted to match the clock frequency. Therefore device can have stable output over the temperature and voltage variation.

DLL has a limitation of locking range and jitter adjustment which are specified as t_{KHKH} and t_{KCvar} respectively in the AC timing characteristics. In order to turn this feature off, applying logic low to the Doff# pin will bypass this. In the DLL off mode, the device behaves with one cycle latency and a longer access time which is known in DDR-I or legacy QUAD mode.

The DLL can also be reset without power down by toggling Doff# pin low to high or stopping the input clocks K and K# for a minimum of 30ns.(K and K# must be stayed either at higher than V_{IH} or lower than V_{IL} level. Remaining V_{ref} is not permitted.) DLL reset must be issued when power up or when clock frequency changes abruptly. After DLL being reset, it gets locked after 2048 cycles of stable clock.

ODT (On Die Termination)

On Die Termination (ODT) is a feature that allows a SRAM to turn on/off termination resistance for ODT pins. The ODT feature is designed to improve signal integrity of the memory channel by allowing the SRAM controller to turn on/off termination resistance independently for any or all SRAM devices.

ODT can have three status, High, Low, and Floating. Each status can have different ODT termination values which tracks the value of RQ (See the picture below) In DDR-IIP devices having common I/O bus, ODT is automatically enabled at the write operation of SRAM and disabled at the read operation of SRAM.

Fig1. Functional representation of ODT

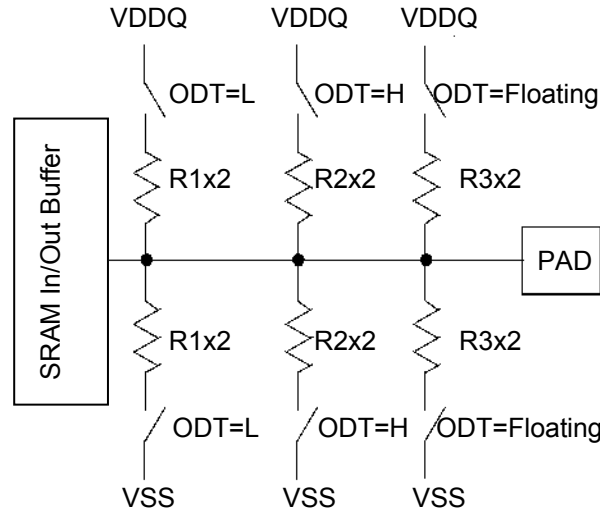

	R1	R2	R3
Option1 ³	0.3x RQ ¹	0.6x RQ ²	0.6x RQ ²
Option2 ⁴	ODT disable	0.6x RQ ²	ODT disable

Notes

1. Allowable range of RQ to guarantee impedance matching a tolerance of ±20% is 175Ω<RQ<350Ω.
2. Allowable range of RQ to guarantee impedance matching a tolerance of ±20% is 175Ω<RQ<250Ω.
3. ODT control pin is connected to VDDQ through 3.5kΩ. Therefore it is recommended to connect it to VSS through less than 100Ω to make it low.
4. ODT control pin is connected to VSS through 3.5kΩ. Therefore it is recommended to connect it to VDDQ through less than 100Ω to make it high.

ODT PIN

1) ODT Pin in option1

- . ODT values of K, K#, DQs, and Wx# are controlled by ODT pin.
- . ODT for DQs will be on and off depending on the status. Read command will turn ODT off as the following rule.

Off: First Read Command + Read Latency - 0.5 cycle

On: Last Read Command + Read Latency + BL/2 cycle + 0.5 cycle (See below timing chart)

Example1) BL=2, RL(Read Latency=2.5)

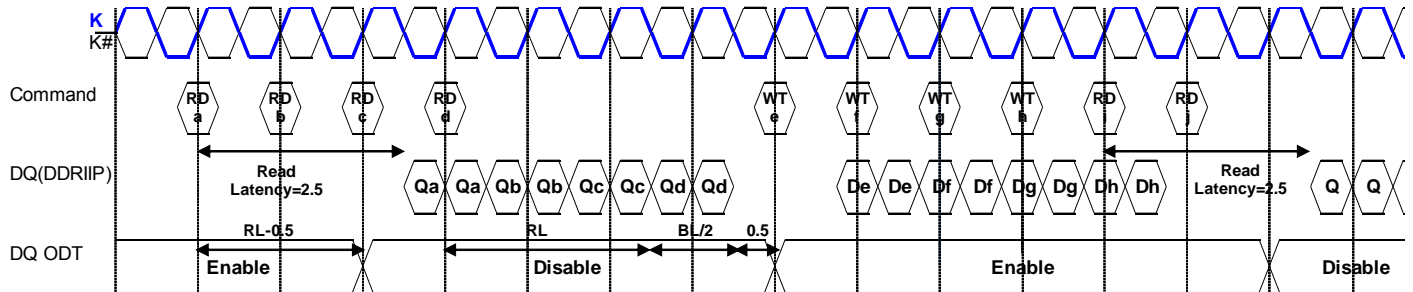

Example2) BL=4, RL(Read Latency=2.5)

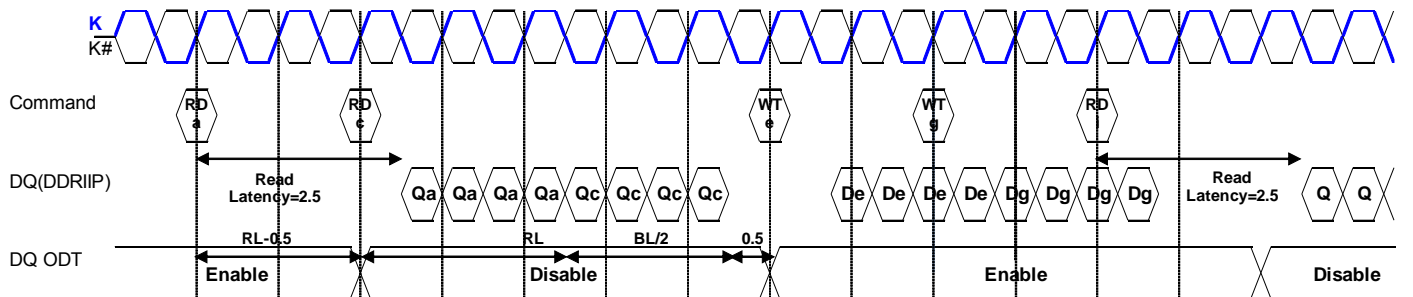

Example3) BL=2, RL(Read Latency=2.0)

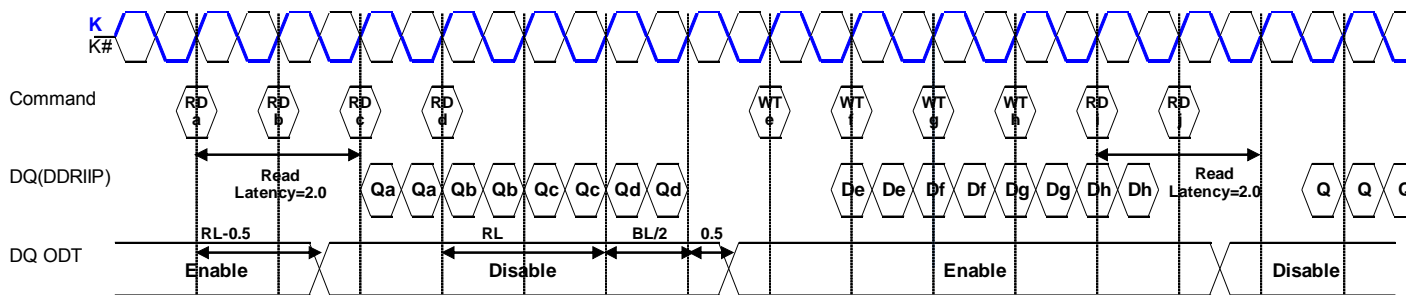

2) ODT Pin in option2

- . Same ODT pin rule of option1 applies except K and K#.

Power-Up and Power-Down Sequences

The recommendation of voltage apply sequence is : $V_{DD} \rightarrow V_{DDQ} \xrightarrow{1)} V_{REF} \xrightarrow{2)} V_{IN}$

Notes:

V_{DDQ} can be applied concurrently with V_{DD} .

V_{REF} can be applied concurrently with V_{DDQ} .

After power and clock signals are stabilized, device can be ready for normal operation after $t_{KC-Lock}$ cycles. In $t_{KC-Lock}$ cycle period, device initializes internal logics and locks DLL. Depending on $/Doff$ status, locking DLL will be skipped. The following timing pictures are possible examples of power up sequence.

Sequence1. /Doff is fixed low

After $t_{KC-Lock}$ cycle of stable clock, device is ready for normal operation.

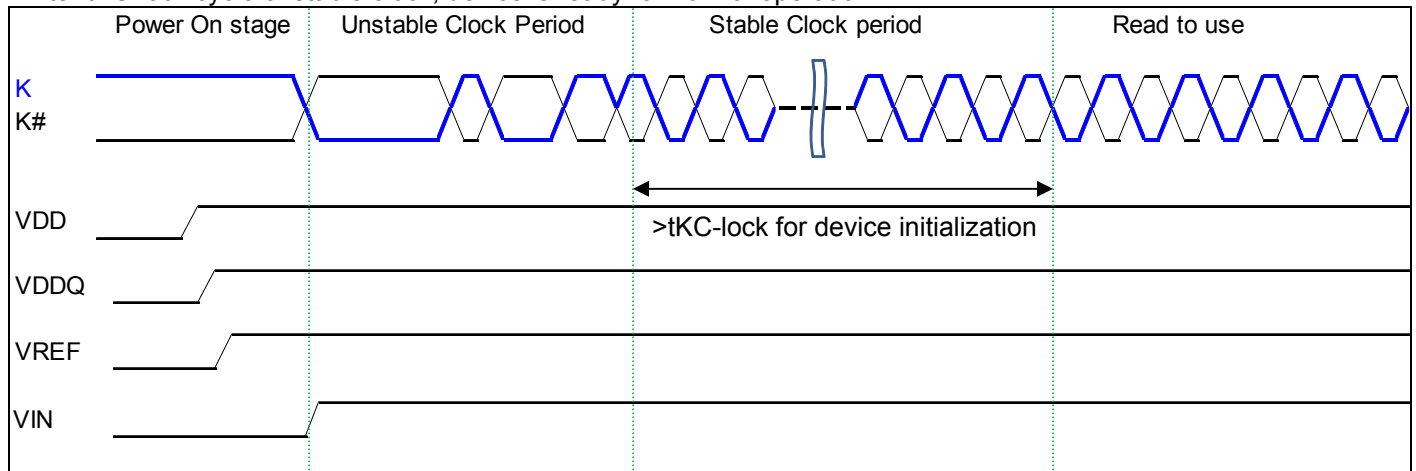

Note) All inputs including clocks must be either logically High or Low during Power On stage. Timing above shows only one of cases.

Sequence2. /Doff is controlled and goes high after clock being stable.

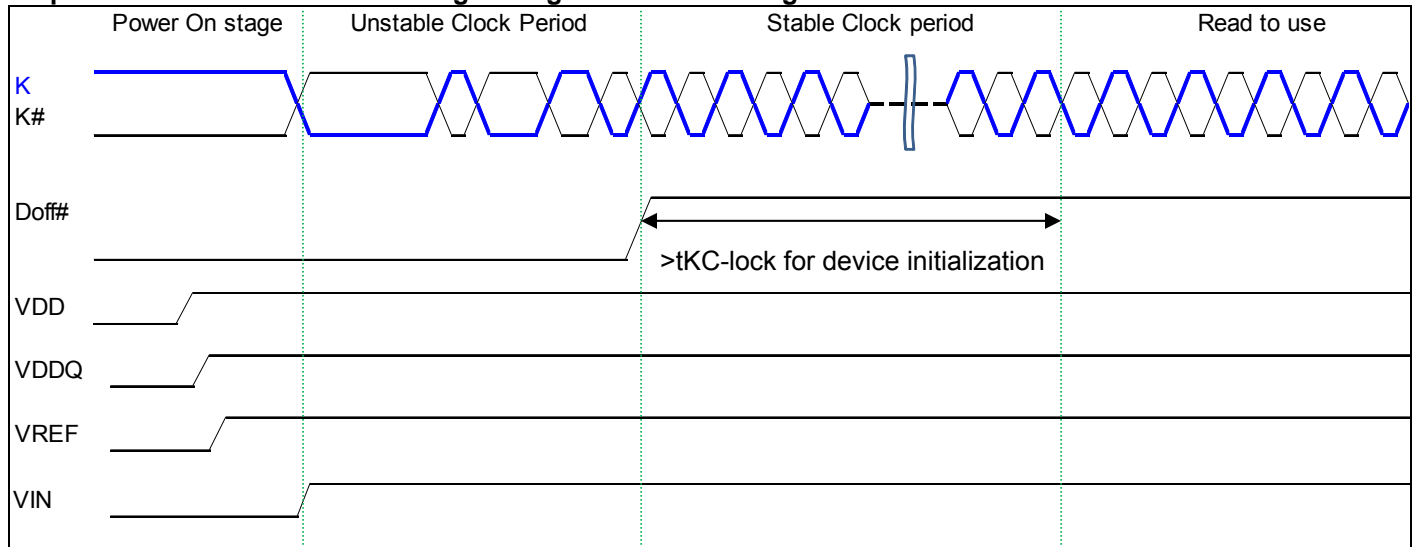

Note) All inputs including clocks must be either logically High or Low during Power On stage. Timing above shows only one of cases.

IS61DDP2B41M18A/A1/A2

IS61DDP2B451236A/A1/A2



Sequence3. /Doff is controlled but goes high before clock being stable.

Because DLL has a risk to be locked with the unstable clock, DLL needs to be reset and locked with the stable input.

a) K-stop to reset. If K or K# stays at VIH or VIL for more than 30nS, DLL will be reset and ready to re-lock. In t_{KC-Lock} period, DLL will be locked with a new stable value. Device can be ready for normal operation after that.

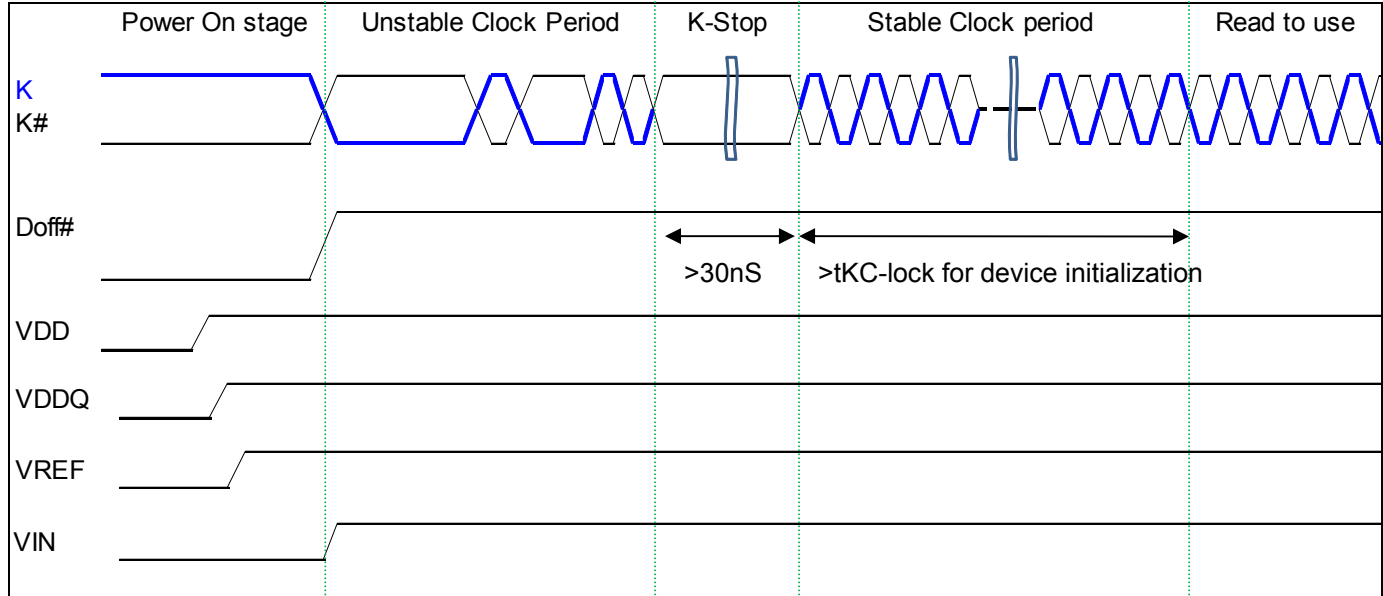

Note) All inputs including clocks must be either logically High or Low during Power On stage. Timing above shows only one of cases.

a) /Doff Low to reset. If /Doff toggled low to high, DLL will be reset and ready to re-lock. In t_{KC-Lock} period, DLL will be locked with a new stable value. Device can be ready for normal operation after that.

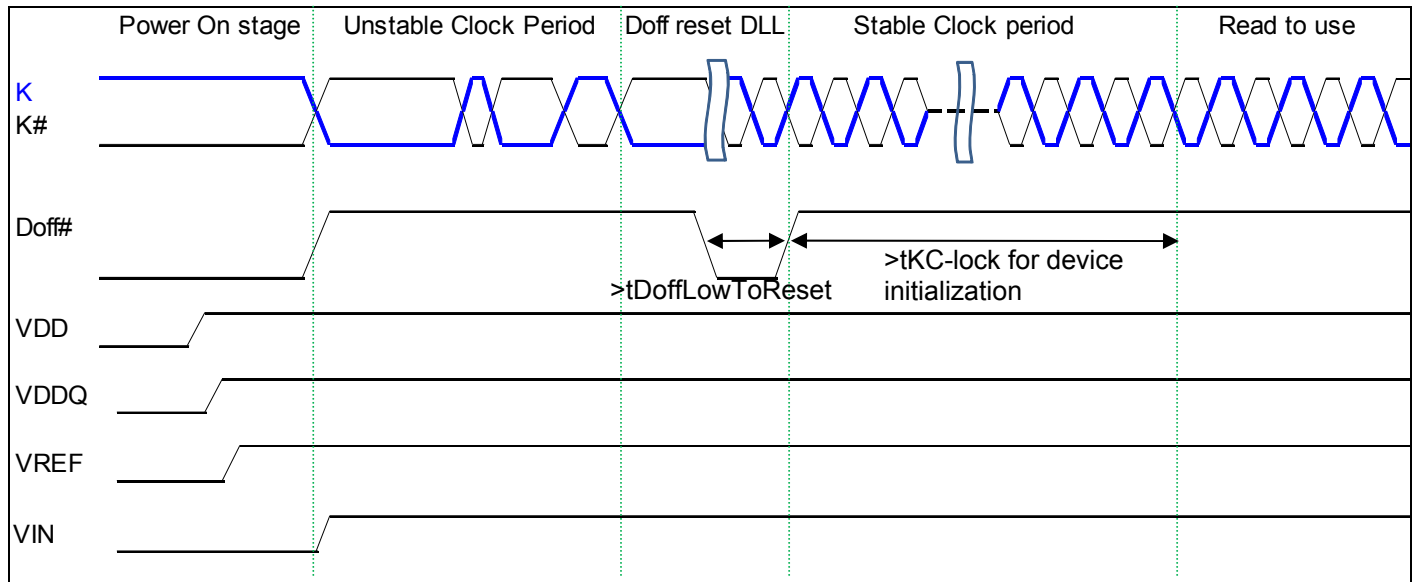

Note) Applying DLL reset sequences (sequence 3a, 3b) are also required when operating frequency is changed without power off.

Note) All inputs including clocks must be either logically High or Low during Power On stage. Timing above shows only one of cases.

Application Example

The following figure depicts an implementation of four 1Mx18 DDR-IIP SRAMs with common I/Os.

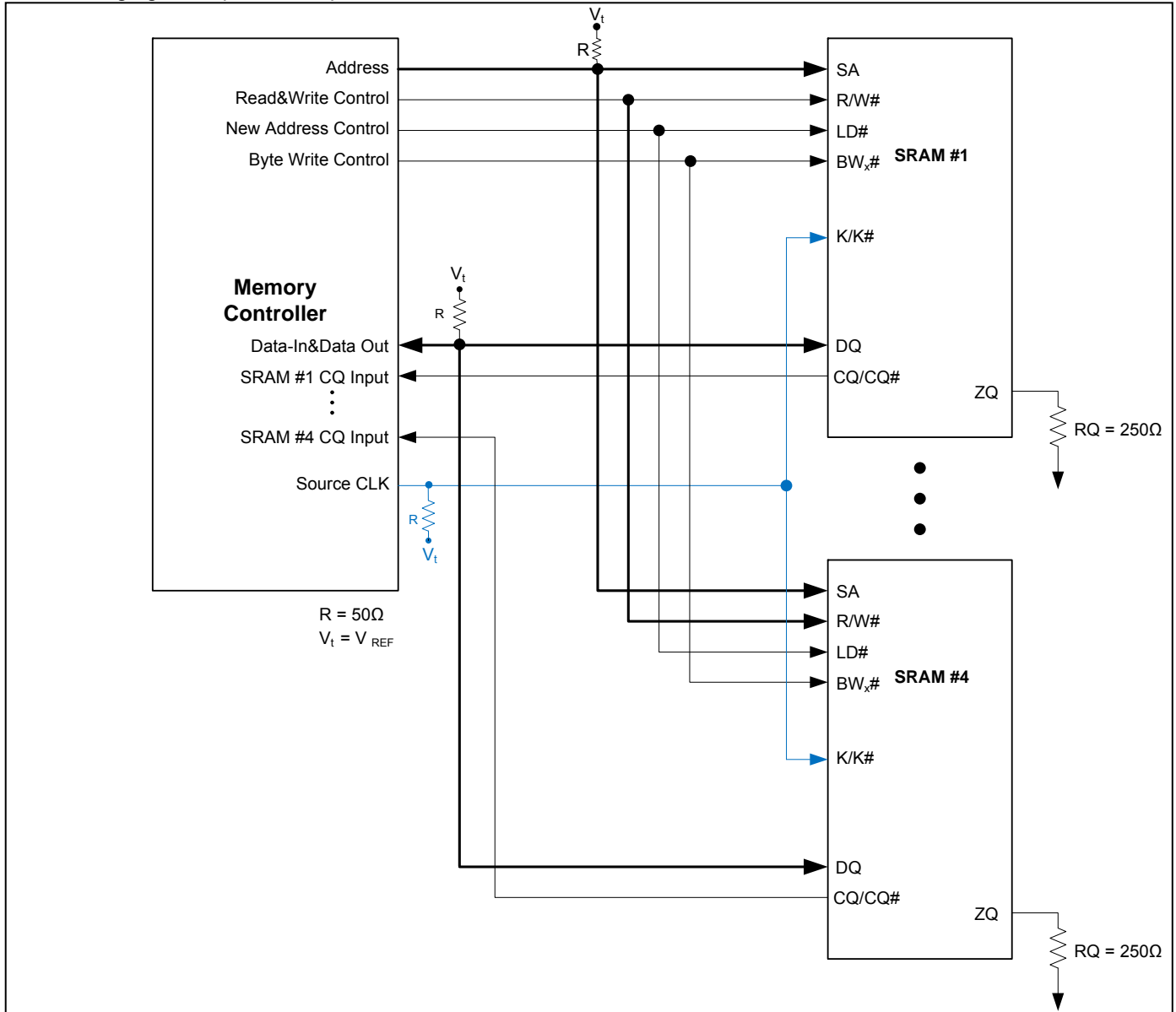

State Diagram

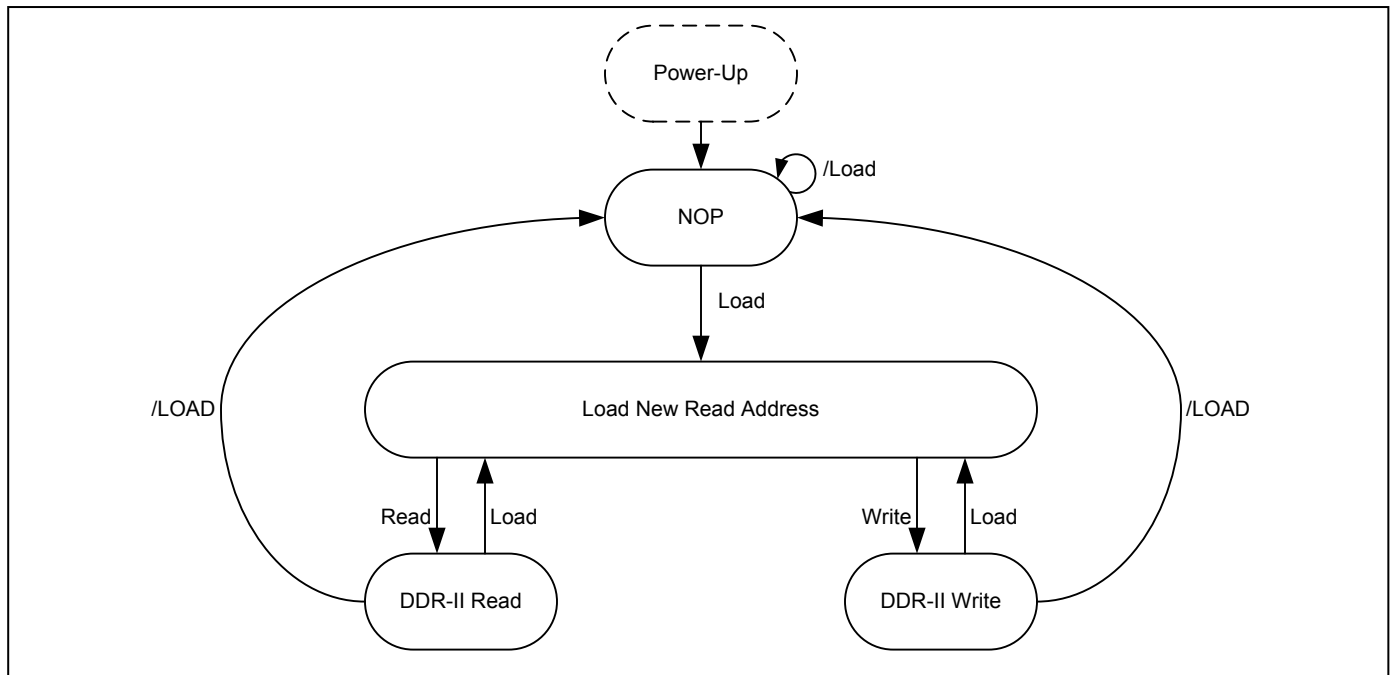

Notes:

1. Internal burst counter is fixed as four-bit linear; that is, when first address is A0+0, continue internal burst addresses are A0+1,A0+2, and A0+3.
2. Read refers to read active status with R/W# = High.
3. Write refers to write active status with R/W# = LOW.
4. Load refers to read new address active status with LD# = low.
5. Load is read new address inactive status with LD = high.

Timing Reference Diagram for Truth Table

The *Timing Reference Diagram for Truth Table* is helpful in understanding the *Clock and Write Truth Tables*, as it shows the cycle relationship between clocks, address, data in, data out, and control signals. Read command is issued at the beginning of cycle “t”. Write command is issued at the beginning of cycle “t+1”.

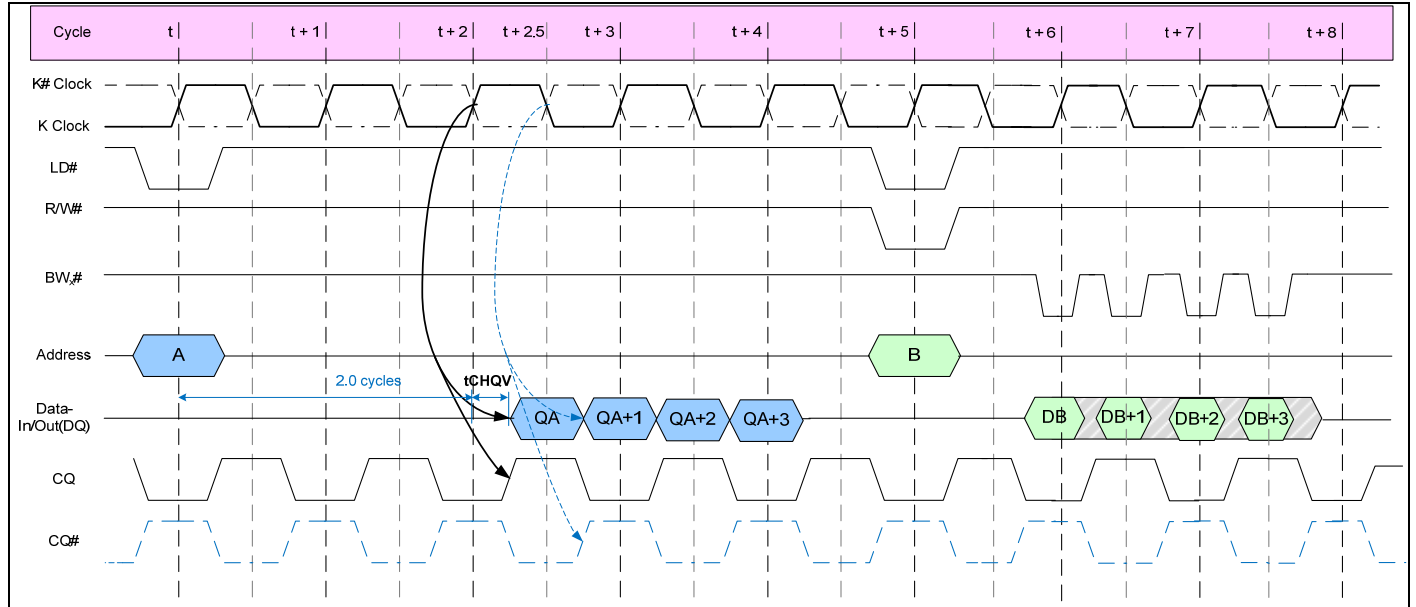

Clock Truth Table

(Use the following table with the *Timing Reference Diagram for Truth Table*.)

Mode	Clock	Controls		Data Out / Data In			
	K	LD#	R/W#	Q _A / D _B	Q _{A+1} / D _{B+1}	Q _{A+2} / D _{B+2}	Q _{A+3} / D _{B+3}
Stop Clock	Stop	X	X	Previous State	Previous State	Previous State	Previous State
No Operation (NOP)	L → H	H	X	High-Z	High-Z	High-Z	High-Z
Read A	L → H	L	H	D _{OUT} at K# (t+2.0) ↑	D _{OUT} at K (t+2.5) ↑	D _{OUT} at K# (t+3.0) ↑	D _{OUT} at K (t+3.5) ↑
Write B	L → H	L	L	D _B at K (t+6.0) ↑	D _B at K# (t+6.5) ↑	D _B at K (t+7.0) ↑	D _B at K# (t+7.5) ↑

Notes:

1. X = “don’t care”; H = logic “1”; L = logic “0”.
2. A read operation is started when control signal R/W# is active high.
3. A write operation is started when control signal R/W# is active low.
4. Before entering into stop clock, all pending read and write commands must be completed.
5. For timing definitions, refer to the *AC Timing Characteristics* table. Signals must meet AC specifications at timings indicated in parenthesis with respect to switching clocks K and K#

IS61DDP2B41M18A/A1/A2

IS61DDP2B451236A/A1/A2



x18 Write Truth Table

(Use the following table with the *Timing Reference Diagram for Truth Table.*)

Operation	K (t+1.0)	K (t+1.5)	K (t+2.0)	K (t+2.5)	BW ₀	BW ₁	D _B	D _{B+1}	D _{B+2}	D _{B+3}
Write Byte 0	L → H				L	H	D0-8 (t+4.0)			
Write Byte 1	L → H				H	L	D9-17 (t+4.0)			
Write All Bytes	L → H				L	L	D0-17 (t+4.0)			
Abort Write	L → H				H	H	Don't Care			
Write Byte 0		L → H			L	H		D0-8 (t+4.5)		
Write Byte 1		L → H			H	L		D9-17 (t+4.5)		
Write All Bytes		L → H			L	L		D0-17 (t+4.5)		
Abort Write		L → H			H	H		Don't Care		
Write Byte 0			L → H		L	H			D0-8 (t+5.0)	
Write Byte 1			L → H		H	L			D9-17 (t+5.0)	
Write All Bytes			L → H		L	L			D0-17 (t+5.0)	
Abort Write			L → H		H	H			Don't Care	
Write Byte 0				L → H	L	H				D0-8 (t+5.5)
Write Byte 1				L → H	H	L				D9-17 (t+5.5)
Write All Bytes				L → H	L	L				D0-17 (t+5.5)
Abort Write				L → H	H	H				Don't Care

Notes:

1. For all cases, R/W# needs to be active low during the rising edge of K occurring at time t.
2. For timing definitions refer to the *AC Timing Characteristics* table. Signals must meet AC specifications with respect to switching clocks K and K#.

IS61DDP2B41M18A/A1/A2

IS61DDP2B451236A/A1/A2



x36 Write Truth Table

(Use the following table with the *Timing Reference Diagram for Truth Table.*)

Operation	K (t+1.0)	K (t+1.5)	K (t+2.0)	K (t+2.5)	BW ₀	BW ₁	BW ₂	BW ₃	D _B	D _{B+1}	D _{B+2}	D _{B+3}
Write Byte 0	L → H				L	H	H	H	D0-8 (t+4.0)			
Write Byte 1	L → H				H	L	H	H	D9-17 (t+4.0)			
Write Byte 2	L → H				H	H	L	H	D18-26 (t+4.0)			
Write Byte 3	L → H				H	H	H	L	D27-35 (t+4.0)			
Write All Bytes	L → H				L	L	L	L	D0-35 (t+4.0)			
Abort Write	L → H				H	H	H	H	Don't Care			
Write Byte 0		L → H			L	H	H	H		D0-8 (t+4.5)		
Write Byte 1		L → H			H	L	H	H		D9-17 (t+4.5)		
Write Byte 2		L → H			H	H	L	H		D18-26 (t+4.5)		
Write Byte 3		L → H			H	H	H	L		D27-35 (t+4.5)		
Write All Bytes		L → H			L	L	L	L		D0-35 (t+4.5)		
Abort Write		L → H			H	H	H	H		Don't Care		
Write Byte 0			L → H		L	H	H	H			D0-8 (t+5.0)	
Write Byte 1			L → H		H	L	H	H			D9-17 (t+5.0)	
Write Byte 2			L → H		H	H	L	H			D18-26 (t+5.0)	
Write Byte 3			L → H		H	H	H	L			D27-35 (t+5.0)	
Write All Bytes			L → H		L	L	L	L			D0-35 (t+5.0)	
Abort Write			L → H		H	H	H	H			Don't Care	
Write Byte 0				L → H	L	H	H	H				D0-8 (t+5.5)
Write Byte 1				L → H	H	L	H	H				D9-17 (t+5.5)
Write Byte 2				L → H	H	H	L	H				D18-26 (t+5.5)
Write Byte 3				L → H	H	H	H	L				D27-35 (t+5.5)
Write All Bytes				L → H	L	L	L	L				D0-35 (t+5.5)
Abort Write				L → H	H	H	H	H				Don't Care

Notes:

1. For all cases, R/W# needs to be active low during the rising edge of K occurring at time t.
2. For timing definitions refer to the *AC Timing Characteristics* table. Signals must meet AC specifications with respect to switching clocks K and K#.

Electrical Specifications

Absolute Maximum Ratings

Parameter	Symbol	Min	Max	Units
Power Supply Voltage	V_{DD}	-0.5	2.9	V
I/O Power Supply Voltage	V_{DDQ}	-0.5	2.9	V
DC Input Voltage	V_{IN}	-0.5	$V_{DD}+0.3$	V
Data Out Voltage	V_{DOUT}	-0.5	2.6	V
Junction Temperature	T_J	-	110	°C
Storage Temperature	T_{STG}	-55	+125	°C

Note:

Stresses greater than those listed in this table can cause permanent damage to the device. This is a stress rating only and functional operation of the device at these or any other conditions above those indicated in the operational sections of this datasheet is not implied. Exposure to absolute maximum rating conditions for extended periods may affect reliability.

Operating Temperature Range

Temperature Range	Symbol	Min	Max	Units
Commercial	T_A	0	+70	°C
Industrial	T_A	-40	+85	°C

DC Electrical Characteristics

(Over the Operating Temperature Range, $V_{DD}=1.8V\pm5\%$)

Parameter	Symbol	Min	Max	Units	Notes
x36 Average Power Supply Operating Current ($I_{OUT}=0$, $V_{IN}=V_{IH}$ or V_{IL})	I_{DD18} I_{DD20} I_{DD22} I_{DD25}	-	1100 960 900 800	mA	1,2
x18 Average Power Supply Operating Current ($I_{OUT}=0$, $V_{IN}=V_{IH}$ or V_{IL})	I_{DD18} I_{DD20} I_{DD22} I_{DD25}	-	1050 910 850 750	mA	1,2
Power Supply Standby Current ($R=V_{IH}$, $W=V_{IH}$. All other inputs= V_{IH} or V_{IL} , $I_{IH}=0$)	I_{SB18} I_{SB20} I_{SB22} I_{SB25}	-	380 360 340 320	mA	1,2
Input leakage current ($0 \leq V_{IN} \leq V_{DDQ}$ for all input balls except V_{REF} , ZQ, TCK, TMS, TDI ball)	I_{LI}	-2	+2	μ A	3,4
Output leakage current ($0 \leq V_{OUT} \leq V_{DDQ}$ for all output balls except TDO ball; Output must be disabled.)	I_{LO}	-2	+2	μ A	
Output "high" level voltage ($I_{OH}=-100\mu$ A, Nominal ZQ)	V_{OH}	$V_{DDQ}-0.2$	V_{DDQ}	V	
Output "low" level voltage ($I_{OL}=100\mu$ A, Nominal ZQ)	V_{OL}	V_{SS}	$V_{SS}+0.2$	V	

Notes:

- I_{OUT} = chip output current.
- The numeric suffix indicates the part operating at speed, as indicated in *AC Timing Characteristics* table (that is, I_{DD25} indicates 2.5ns cycle time).
- ODT must be disabled.
- Balls with ODT and DOFF# do not follow this spec, $I_{LI} = \pm 5\mu$ A.

IS61DDP2B41M18A/A1/A2

IS61DDP2B451236A/A1/A2



Recommended DC Operating Conditions

(Over the Operating Temperature Range)

Parameter	Symbol	Min	Typical	Max	Units	Notes
Supply Voltage	V_{DD}	1.8–5%	1.8	1.8+5%	V	1
Output Driver Supply Voltage	V_{DDQ}	1.4	1.5	V_{DD}	V	1
Input High Voltage	V_{IH}	$V_{REF}+0.1$	-	$V_{DDQ}+0.2$	V	1, 2
Input Low Voltage	V_{IL}	-0.2	-	$V_{REF}-0.1$	V	1, 3
Input Reference Voltage	V_{REF}	0.68	0.75	0.95	V	1, 5
Clock Signal Voltage	V_{IN-CLK}	-0.2	-	$V_{DDQ}+0.2$	V	1, 4

Notes:

- All voltages are referenced to V_{SS} . All V_{DD} , V_{DDQ} , and V_{SS} pins must be connected.
- $V_{IH(max)}$ AC = See *Overshoot and Undershoot Timings*.
- $V_{IL(min)}$ AC = See *Overshoot and Undershoot Timings*.
- V_{IN-CLK} specifies the maximum allowable DC excursions of each clock (K and K#).
- Peak-to-peak AC component superimposed on V_{REF} may not exceed 5% of V_{REF} .

Overshoot and Undershoot Timings

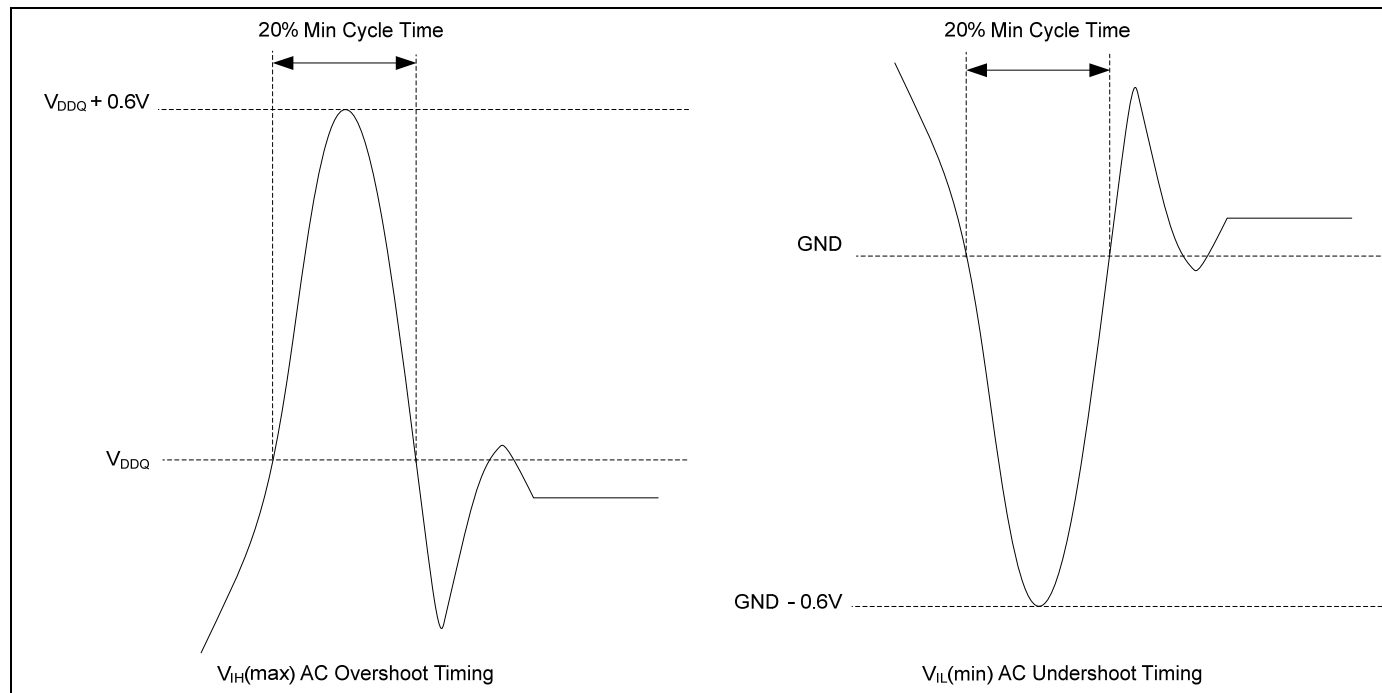

Typical AC Input Characteristics

Parameter	Symbol	Min	Max	Units	Notes
AC Input Logic HIGH	$V_{IH} (AC)$	$V_{REF}+0.2$		V	1, 2, 3, 4
AC Input Logic LOW	$V_{IL} (AC)$		$V_{REF}-0.2$	V	1, 2, 3, 4
Clock Input Logic HIGH	$V_{IH-CLK} (AC)$	$V_{REF}+0.2$		V	1, 2, 3
Clock Input Logic LOW	$V_{IL-CLK} (AC)$		$V_{REF}-0.2$	V	1, 2, 3

Notes:

1. The peak-to-peak AC component superimposed on V_{REF} may not exceed 5% of the DC component of V_{REF} .
2. Performance is a function of V_{IH} and V_{IL} levels to clock inputs.
3. See the *AC Input Definition* diagram.
4. See the *AC Input Definition* diagram. The signals should swing monotonically with no steps rail-to-rail with input signals never ringing back past $V_{IH} (AC)$ and $V_{IL} (AC)$ during the input setup and input hold window. $V_{IH} (AC)$ and $V_{IL} (AC)$ are used for timing purposes only.

AC Input Definition

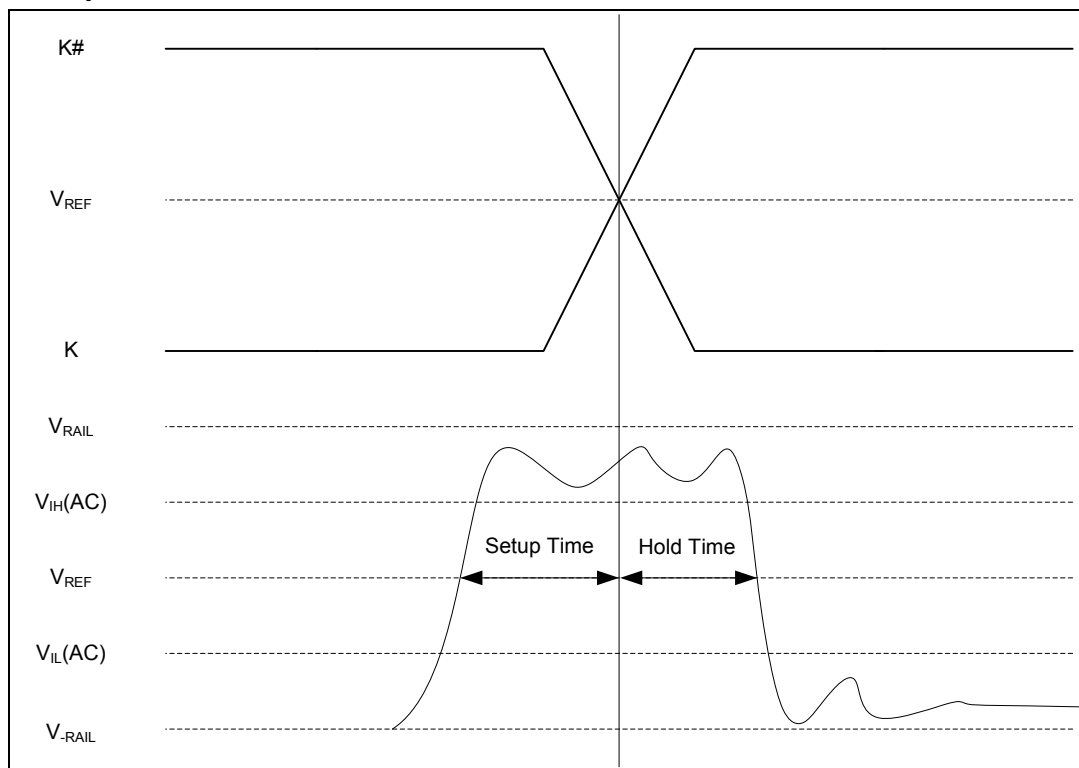

PBGA Thermal Characteristics

Parameter	Symbol	Rating	Units
Thermal resistance from junction to ambient (airflow = 1m/s)	$R_{\theta JA}$	TBD	$^{\circ}C/W$
Thermal resistance from junction to pins	$R_{\theta JB}$	TBD	$^{\circ}C/W$
Thermal resistance from junction to case	$R_{\theta JC}$	TBD	$^{\circ}C/W$

Note: these parameters are guaranteed by design and tested by a sample basis only.

Pin Capacitance

Parameter	Symbol	Test Condition	Max	Units
Input or output capacitance except DQ pins	C_{IN}, C_O	$T_A = 25^\circ\text{C}, f = 1\text{ MHz}, V_{DD} = 1.8\text{V}, V_{DDQ} = 1.5\text{V}$	5	pF
DQ capacitance (DQ0–DQx)	C_{DQ}		6	pF
Clocks Capacitance (K, K#)	C_{CLK}		4	pF

Note: these parameters are guaranteed by design and tested by a sample basis only.

Programmable Impedance Output Driver DC Electrical Characteristics

(Over the Operating Temperature Range, $V_{DD}=1.8\text{V}\pm 5\%$, $V_{DDQ}=1.5\text{V}/1.8\text{V}$)

Parameter	Symbol	Min	Max	Units	Notes
Output Logic HIGH Voltage	V_{OH}	$V_{DDQ}/2 - 0.12$	$V_{DDQ}/2 + 0.12$	V	1, 3
Output Logic LOW Voltage	V_{OL}	$V_{DDQ}/2 - 0.12$	$V_{DDQ}/2 + 0.12$	V	2, 3

Notes:

1. For $175\Omega \leq R_Q \leq 350\Omega$:

$$|I_{OH}| = \frac{\left(\frac{V_{DDQ}}{2}\right)}{\left(\frac{R_Q}{5}\right)}$$

2. For $175\Omega \leq R_Q \leq 350\Omega$:

$$|I_{OL}| = \frac{\left(\frac{V_{DDQ}}{2}\right)}{\left(\frac{R_Q}{5}\right)}$$

3. Parameter Tested with $R_Q=250\Omega$ and $V_{DDQ}=1.5\text{V}$

AC Test Conditions

(Over the Operating Temperature Range, $V_{DD}=1.8\text{V}\pm 5\%$, $V_{DDQ}=1.5\text{V}/1.8\text{V}$)

Parameter	Symbol	Conditions	Units	Notes
Output Drive Power Supply Voltage	V_{DDQ}	1.5/1.8	V	
Input Logic HIGH Voltage	V_{IH}	$V_{REF}+0.5$	V	
Input Logic LOW Voltage	V_{IL}	$V_{REF}-0.5$	V	
Input Reference Voltage	V_{REF}	0.75/0.9	V	
Input Rise Time	T_R	2.0	V/ns	
Input Fall Time	T_F	2.0	V/ns	
Output Timing Reference Level		V_{REF}	V	
Clock Reference Level		V_{REF}	V	
Output Load Conditions				1, 2

Notes:

- See AC Test Loading.
- Parameter Tested with $R_Q=250\Omega$ and $V_{DDQ}=1.5\text{V}$

AC Test Loading

(a) Unless otherwise noted, AC test loading assume this condition.

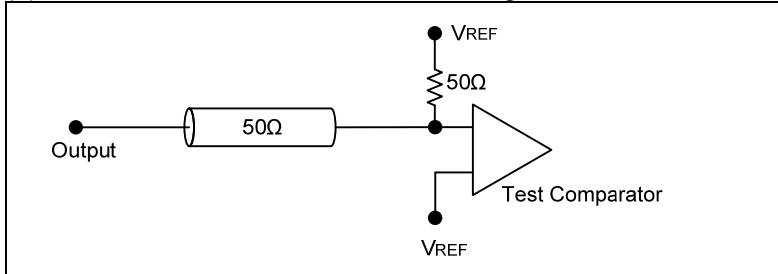

(b) t_{CHQZ} and t_{CHQX1} are specified with 5pF load capacitance and measured when transition occurs $\pm 100\text{mV}$ from the steady state voltage.

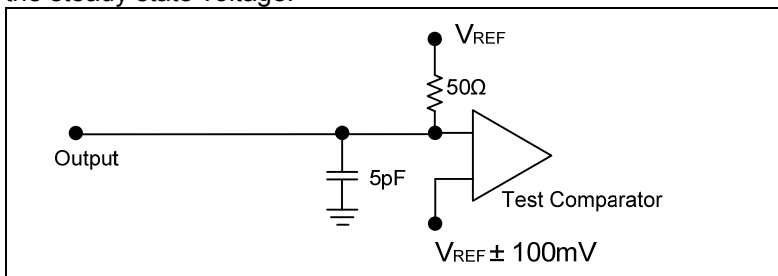

(c) TDO

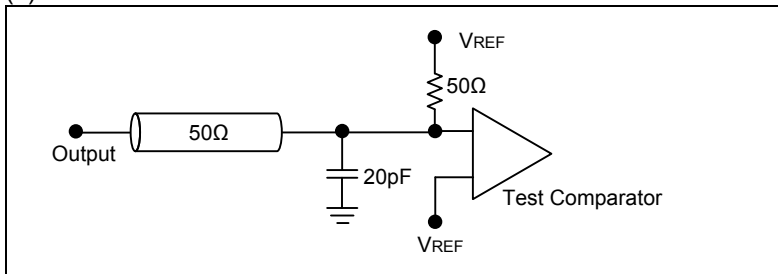

IS61DDP2B41M18A/A1/A2

IS61DDP2B451236A/A1/A2



AC Timing Characteristics

(Over the Operating Temperature Range, $V_{DD}=1.8V\pm5\%$, $V_{DDQ}=1.5V/1.8V$)

Parameter	Symbol	18 (550MHz)		20 (500MHz)		22 (450MHz)		25 (400MHz)		Units	Notes
		Min	Max	Min	Max	Min	Max	Min	Max		
Clock											
Clock Cycle Time (K, K#)	tKHKH	1.82	8.40	2.00	8.40	2.2	8.40	2.50	8.40	ns	
Clock Phase Jitter (K, K#)	tKC var		0.15		0.15		0.15		0.20	ns	4
Clock High Time (K, K#)	tKHKL	0.4		0.4		0.4		0.4		cycle	
Clock Low Time (K, K#)	tKLKH	0.4		0.4		0.4		0.4		cycle	
Clock to Clock# (K, K#)	tKHK#H	0.82		0.90		0.99		1.13		ns	
DLL Lock Time (K)	tKC lock	2048		2048		2048		2048		cycles	5
Doff Low period to DLL reset	tDoffLowToReset	5		5		5		5		ns	
K static to DLL reset	tKcreset	30		30		30		30		ns	
Output Times											
K, K# High to Output Valid	tCHQV		0.45		0.45		0.45		0.45	ns	
K, K# High to Output Hold	tCHQX	-0.45		-0.45		-0.45		-0.45		ns	
K, K# High to Echo Clock Valid	tCHCQV		0.45		0.45		0.45		0.45	ns	
K, K# High to Echo Clock Hold	tCHCQX	-0.45		-0.45		-0.45		-0.45		ns	
CQ, CQ# High to Output Valid	tCQHQV		0.15		0.15		0.2		0.2	ns	6
CQ, CQ# High to Output Hold	tCQHQX	-0.15		-0.15		-0.2		-0.2		ns	6
K, High to Output High-Z	tCHQZ		0.45		0.45		0.45		0.45	ns	
K, High to Output Low-Z	tCHQX1	-0.45		-0.45		-0.45		-0.45		ns	
CQ, CQ# High to QVLD Valid	tQVLD	-0.15	0.15	-0.15	0.15	-0.20	0.20	-0.20	0.20	ns	
Setup Times											
Address valid to K rising edge	tAVKH	0.23		0.25		0.30		0.40		ns	
R#,W# control inputs valid to K rising edge	tIVKH	0.23		0.25		0.30		0.40		ns	2
BW,# control inputs valid to K rising edge	tIVKH2	0.18		0.20		0.25		0.28		ns	2
Data-in valid to K, K# rising edge	tDVKH	0.18		0.20		0.25		0.28		ns	
Hold Times											
K rising edge to address hold	tKHAX	0.23		0.25		0.30		0.40		ns	2
K rising edge to R#,W# control inputs hold	tKHIX	0.23		0.25		0.30		0.40		ns	2
K rising edge to BW,# control inputs hold	tKHIX2	0.18		0.20		0.25		0.28		ns	
K, K# rising edge to data-in hold	tKHDX	0.18		0.20		0.25		0.28		ns	

Notes:

1. All address inputs must meet the specified setup and hold times for all latching clock edges.
2. During normal operation, VIH, VIL, TRISE, and TFALL of inputs must be within 20% of VIH, VIL, TRISE, and TFALL of clock.
3. Clock phase jitter is the variance from clock rising edge to the next expected clock rising edge.
4. V_{DD} slew rate must be less than 0.1V DC per 50ns for DLL lock retention. DLL lock time begins once V_{DD} and input clock are stable.
5. The data sheet parameters reflect tester guard bands and test setup variations.
6. To avoid bus contention, at a given voltage and temperature tCHQX1 is bigger than tCHQZ. The specs as shown do not imply bus contention because tCHQX1 is a MIN parameter that is worst case at totally different test conditions (0 C, 1.9V) than tCHQZ, which is a MAX parameter (worst case at 70 C, 1.7V) It is not possible for two SRAMs on the same board to be at such different voltage and temperature.

IS61DDP2B41M18A/A1/A2 IS61DDP2B451236A/A1/A2



Read, Write, and NOP Timing Diagram

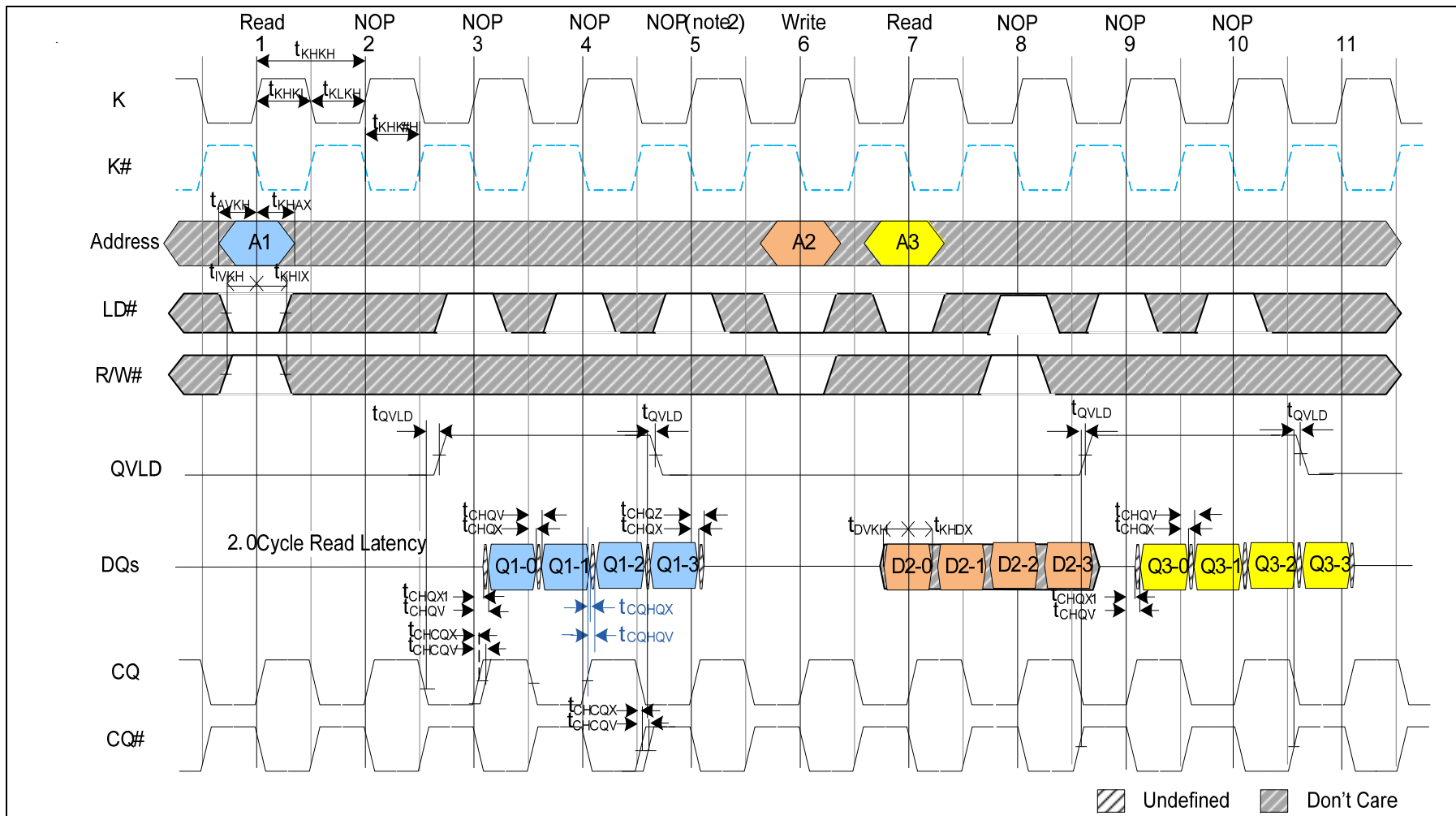

Notes: 1. Q1-0 refers to the output from address A1. Q1-1, Q1-2, and Q1-3 refer to the output from the next burst address following A1.
2. The NOP cycle is not necessary for correct device operation, however, at high clock frequencies, it might be required to prevent bus contention.

IEEE 1149.1 TAP and Boundary Scan

The SRAM provides a limited set of JTAG functions to test the interconnection between SRAM I/Os and printed circuit board traces or other components. There is no multiplexer in the path from I/O pins to the RAM core.

In conformance with IEEE Standard 1149.1, the SRAM contains a TAP controller, instruction register, boundary scan register, bypass register, and ID register.

The TAP controller has a standard 16-state machine that resets internally on power-up. Therefore, a TRST signal is not required.

Disabling the JTAG feature

The SRAM can operate without using the JTAG feature. To disable the TAP controller, TCK must be tied LOW (VSS) to prevent clocking of the device. TDI and TMS are internally pulled up and may be left disconnected. They may alternately be connected to VDD through a pull-up resistor. TDO should be left disconnected. On power-up, the device will come up in a reset state, which will not interfere with device operation.

Test Access Port Signal List:

1. Test Clock (TCK)

This signal uses VDD as a power supply. The test clock is used only with the TAP controller. All inputs are captured on the rising edge of TCK. All outputs are driven from the falling edge of TCK.

2. Test Mode Select (TMS)

This signal uses VDD as a power supply. The TMS input is used to send commands to the TAP controller and is sampled on the rising edge of TCK.

3. Test Data-In (TDI)

This signal uses VDD as a power supply. The TDI input is used to serially input test instructions and information into the registers and can be connected to the input of any of the registers. The register between TDI and TDO is chosen by the instruction that is loaded into the TAP instruction register. TDI is connected to the most significant bit (MSB) of any register. For more information regarding instruction register loading, please see the TAP Controller State Diagram.

4. Test Data-Out (TDO)

This signal uses VDDQ as a power supply. The TDO output ball is used to serially clock test instructions and data out from the registers. The TDO output driver is only active during the Shift-IR and Shift-DR TAP controller states. In all other states, the TDO pin is in a High-Z state. The output changes on the falling edge of TCK. TDO is connected to the least significant bit (LSB) of any register. For more information, please see the TAP Controller State Diagram.

TAP Controller State and Block Diagram

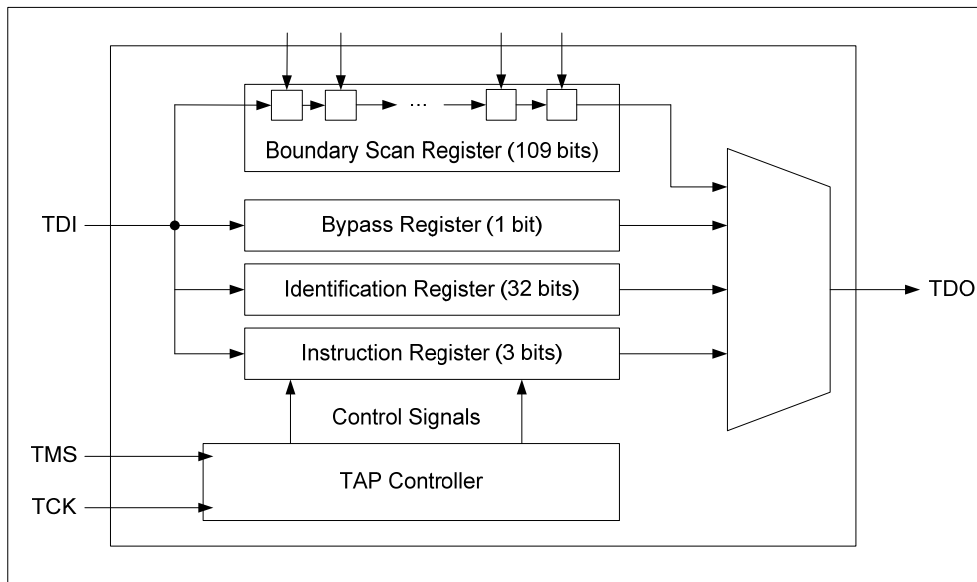

TAP Controller State Machine

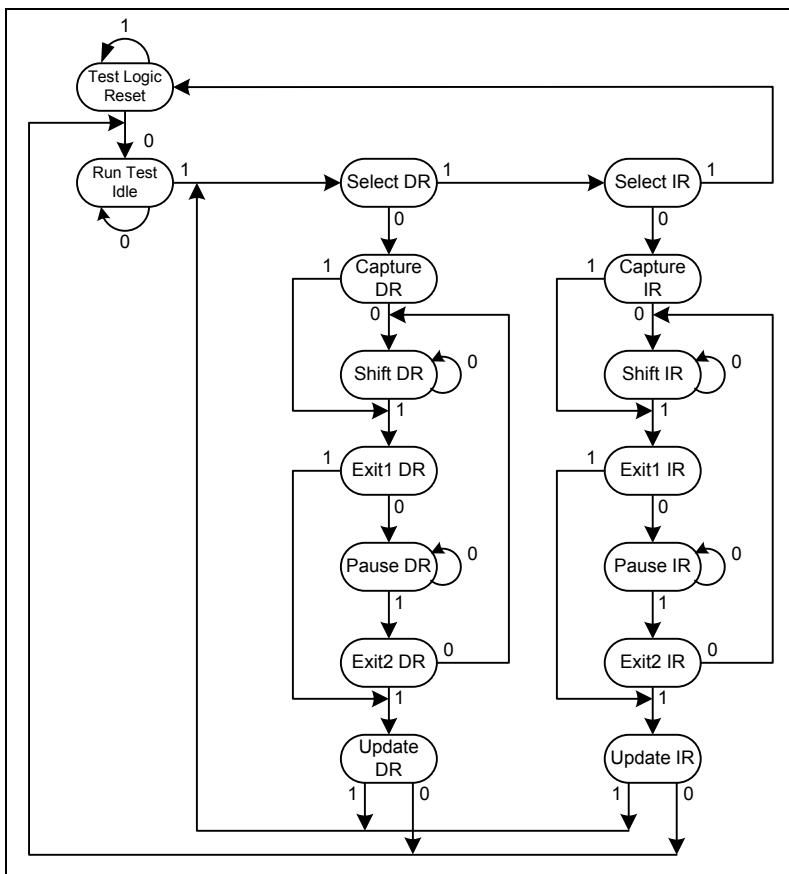

Performing a TAP Reset

A Reset is performed by forcing TMS HIGH (VDD) for five rising edges of TCK. RESET may be performed while the SRAM is operating and does not affect its operation. At power-up, the TAP is internally reset to ensure that TDO comes up in a high-Z state.

TAP Registers

Registers are connected between the TDI and TDO pins and allow data to be scanned into and out of the SRAM test circuitry. Only one register can be selected at a time through the instruction registers. Data is serially loaded into the TDI pin on the rising edge of TCK and output on the TDO pin on the falling edge of TCK.

1. Instruction Register

This register is loaded during the update-IR state of the TAP controller. At power-up, the instruction register is loaded with the IDCODE instruction. It is also loaded with the IDCODE instruction if the controller is placed in a reset state as described in the previous section. When the TAP controller is in the capture-IR state, the two LSBs are loaded with a binary "01" pattern to allow for fault isolation of the board-level serial test data path.

2. Bypass Register

The bypass register is a single-bit register that can be placed between the TDI and TDO balls. This allows data to be shifted through the SRAM with minimal delay. The bypass register is set LOW (V_{SS}) when the BYPASS instruction is executed.

3. Boundary Scan Register

The boundary scan register is connected to all the input and bidirectional balls on the SRAM. Several balls are also included in the scan register to reserved balls. The boundary scan register is loaded with the contents of the SRAM Input and Output ring when the TAP controller is in the capture-DR state and is then placed between the TDI and TDO balls when the controller is moved to the shift-DR state. Each bit corresponds to one of the balls on the SRAM package. The MSB of the register is connected to TDI, and the LSB is connected to TDO.

4. Identification (ID) Register

The ID register is loaded with a vendor-specific, 32-bit code during the capture-DR state when the IDCODE command is loaded in the instruction register. The IDCODE is hardwired into the SRAM and can be shifted out when the TAP controller is in the shift-DR state.

Scan Register Sizes

Register Name	Bit Size
Instruction	3
Bypass	1
ID	32
Boundary Scan	109

TAP Instruction Set

Many instructions are possible with an eight-bit instruction register and all valid combinations are listed in the TAP Instruction Code Table. All other instruction codes that are not listed on this table are reserved and should not be used. Instructions are loaded into the TAP controller during the Shift-IR state when the instruction register is placed between TDI and TDO. During this state, instructions are shifted from the instruction register through the TDI and TDO pins. To execute an instruction once it is shifted in, the TAP controller must be moved into the Update-IR state.

1. EXTEST

The EXTEST instruction allows circuitry external to the component package to be tested. Boundary-scan register cells at output balls are used to apply a test vector, while those at input balls capture test results. Typically, the first test vector to be applied using the EXTEST instruction will be shifted into the boundary scan register using the PRELOAD

IS61DDP2B41M18A/A1/A2

IS61DDP2B451236A/A1/A2



instruction. Thus, during the update-IR state of EXTEST, the output driver is turned on, and the PRELOAD data is driven onto the output balls.

2. IDCODE

The IDCODE instruction causes a vendor-specific, 32-bit code to be loaded into the instruction register. It also places the instruction register between the TDI and TDO balls and allows the IDCODE to be shifted out of the device when the TAP controller enters the shift-DR state. The IDCODE instruction is loaded into the instruction register upon power-up or whenever the TAP controller is given a test logic reset state.

3. SAMPLE Z

If the SAMPLE-Z instruction is loaded in the instruction register, all SRAM outputs are forced to an inactive drive state (high-Z), moving the TAP controller into the capture-DR state loads the data in the SRAMs input into the boundary scan register, and the boundary scan register is connected between TDI and TDO when the TAP controller is moved to the shift-DR state.

4. SAMPLE/PRELOAD

When the SAMPLE/PRELOAD instruction is loaded into the instruction register and the TAP controller is in the capture-DR state, a snapshot of data on the inputs and bidirectional balls is captured in the boundary scan register. The user must be aware that the TAP controller clock can only operate at a frequency up to 50 MHz, while the SRAM clock operates significantly faster. Because there is a large difference between the clock frequencies, it is possible that during the capture-DR state, an input or output will undergo a transition. The TAP may then try to capture a signal while in transition. This will not harm the device, but there is no guarantee as to the value that will be captured. Repeatable results may not be possible. To ensure that the boundary scan register will capture the correct value of a signal, the SRAM signal must be stabilized long enough to meet the TAP controller's capture setup plus hold time. The SRAM clock input might not be captured correctly if there is no way in a design to stop (or slow) the clock during a SAMPLE/ PRELOAD instruction. If this is an issue, it is still possible to capture all other signals and simply ignore the value of the CK and CK# captured in the boundary scan register. Once the data is captured, it is possible to shift out the data by putting the TAP into the shift-DR state. This places the boundary scan register between the TDI and TDO balls.

6. BYPASS

When the BYPASS instruction is loaded in the instruction register and the TAP is placed in a shift-DR state, the bypass register is placed between TDI and TDO. The advantage of the BYPASS instruction is that it shortens the boundary scan path when multiple devices are connected together on a board.

7. PRIVATE

Do not use these instructions. They are reserved for future use and engineering mode.

JTAG DC Operating Characteristics

(Over the Operating Temperature Range, $V_{DD}=1.8V\pm5\%$)

Parameter	Symbol	Min	Max	Units	Notes
JTAG Input High Voltage	V_{IH1}	1.3	$V_{DD}+0.3$	V	
JTAG Input Low Voltage	V_{IL1}	-0.3	0.5	V	
JTAG Output High Voltage	V_{OH1}	1.4	-	V	$ I_{OH1} =2mA$
JTAG Output Low Voltage	V_{OL1}	-	0.4	V	$I_{OL1}=2mA$
JTAG Output High Voltage	V_{OH2}	1.6	-	V	$ I_{OH2} =100\mu A$
JTAG Output Low Voltage	V_{OL2}	-	0.2	V	$I_{OL2}=100\mu A$
JTAG Input Leakage Current	I_{LIJTAG}	-5	+5	μA	$0 \leq V_{in} \leq V_{DD}$
JTAG Output Leakage Current	I_{LOJTAG}	-5	+5	μA	$0 \leq V_{out} \leq V_{DD}$

Notes:

- All voltages referenced to VSS (GND); All JTAG inputs and outputs are LVTTTL-compatible.
- In "EXTEST" mode and "SAMPLE" mode, V_{DDQ} is nominally 1.5 V.

JTAG AC Test Conditions

(Over the Operating Temperature Range, $V_{DD}=1.8V\pm5\%$, $V_{DDQ}=1.5V/1.8V$)

Parameter	Symbol	Conditions	Units
Input Pulse High Level	V_{IH1}	1.3	V
Input Pulse Low Level	V_{IL1}	0.5	V
Input Rise Time	T_{R1}	1.0	ns
Input Fall Time	T_{F1}	1.0	ns
Input and Output Timing Reference Level		0.9	V

JTAG AC Characteristics

(Over the Operating Temperature Range, $V_{DD}=1.8V\pm5\%$, $V_{DDQ}=1.5V/1.8V$)

Parameter	Symbol	Min	Max	Units
TCK cycle time	t_{THTH}	50	–	ns
TCK high pulse width	t_{THTL}	20	–	ns
TCK low pulse width	t_{TLTH}	20	–	ns
TMS Setup	t_{MVTH}	5	–	ns
TMS Hold	t_{THMX}	5	–	ns
TDI Setup	t_{DVTH}	5	–	ns
TDI Hold	t_{THDX}	5	–	ns
TCK Low to Valid Data*	t_{TLOV}	–	10	ns

Note: See AC Test Loading(c)

JTAG Timing Diagram

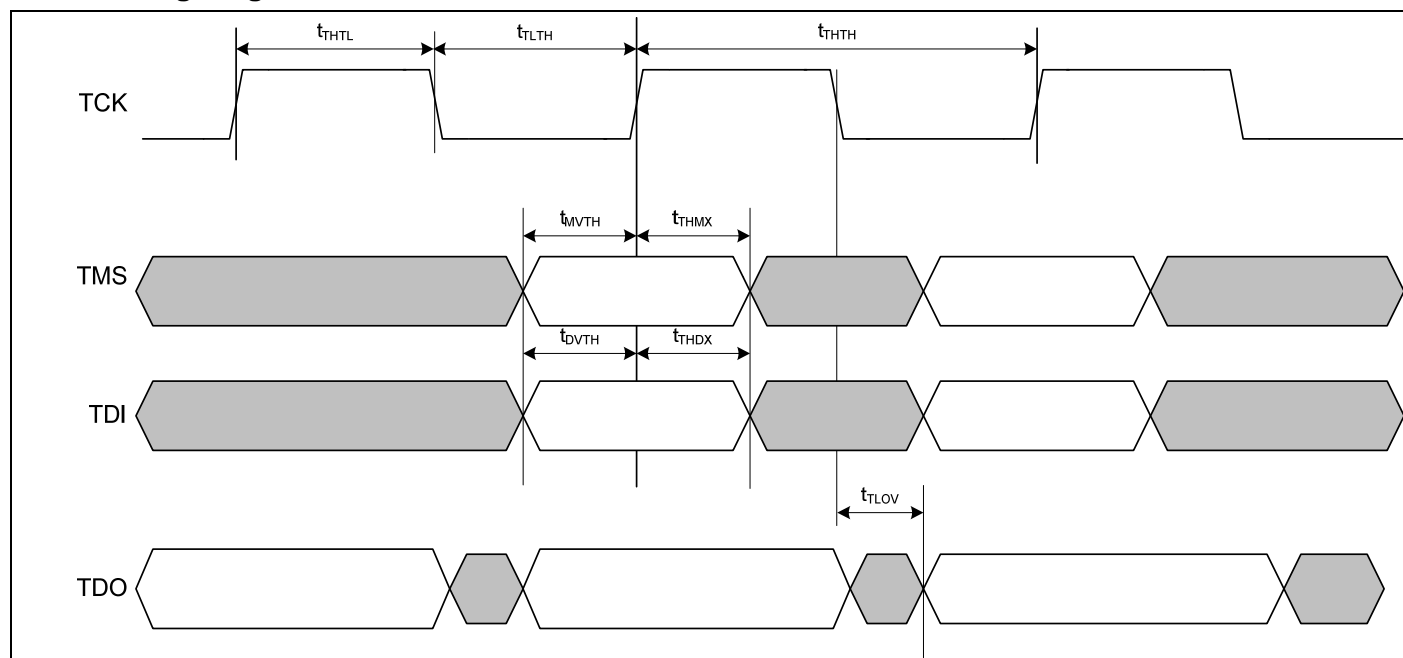

Instruction Set

Code	Instruction	TDO Output	Notes
000	EXTEST	Boundary Scan Register	2, 6
001	IDCODE	32-bit Identification Register	
010	SAMPLE-Z	Boundary Scan Register	1, 2
011	PRIVATE	Do Not Use	5
100	SAMPLE(/PRELOAD)	Boundary Scan Register	4
101	PRIVATE	Do Not Use	5
110	PRIVATE	Do Not Use	5
111	BYPASS	Bypass Register	3

Notes:

- Places Qs in high-Z in order to sample all input data, regardless of other SRAM inputs.
- TDI is sampled as an input to the first ID register to allow for the serial shift of the external TDI data.
- BYPASS register is initiated to V_{SS} when BYPASS instruction is invoked. The BYPASS register also holds the last serially loaded TDI when exiting the shift-DR state.
- SAMPLE instruction does not place Qs in high-Z.
- This instruction is reserved. Invoking this instruction will cause improper SRAM functionality.
- This EXTEST is not IEEE 1149.1-compliant. By default, it places Q in high-Z. If the internal register on the scan chain is set high, Q will be updated with information loaded via a previous SAMPLE instruction. The actual transfer occurs during the update IR state after EXTEST is loaded. The value of the internal register can be changed during SAMPLE and EXTEST only.

ID Register Definition

Revision Number (31:29)	Part Configuration (28:12)	JEDEC Code (11:1)	Start Bit (0)
000	00DEF0WX01PQLB0S0	00011010101	1

Part Configuration Definition:

- DEF = 001 for 18Mb
- WX = 11 for x36, 10 for x18
- P = 1 for II+(QUADP/DDR-IIP), 0 for II(QUAD/DDR-II)
- Q = 1 for QUAD, 0 for DDR-II
- L = 1 for RL=2.5, 0 for RL≠2.5
- B = 1 for burst of 4, 0 for burst of 2
- S = 1 for Separate I/O, 0 for Common I/O

LIST OF IEEE 1149.1 STANDARD VIOLATIONS

- 7.2.1.b, e
- 7.7.1.a-f
- 10.1.1.b, e
- 10.7.1.a-d
- 6.1.1.d

IS61DDP2B41M18A/A1/A2

IS61DDP2B451236A/A1/A2



Boundary Scan Exit Order

ORDER	Pin ID
1	6R
2	6P
3	6N
4	7P
5	7N
6	7R
7	8R
8	8P
9	9R
10	11P
11	10P
12	10N
13	9P
14	10M
15	11N
16	9M
17	9N
18	11L
19	11M
20	9L
21	10L
22	11K
23	10K
24	9J
25	9K
26	10J
27	11J
28	11H
29	10G
30	9G
31	11F
32	11G
33	9F
34	10F
35	11E
36	10E

ORDER	Pin ID
37	10D
38	9E
39	10C
40	11D
41	9C
42	9D
43	11B
44	11C
45	9B
46	10B
47	11A
48	10A
49	9A
50	8B
51	7C
52	6C
53	8A
54	7A
55	7B
56	6B
57	6A
58	5B
59	5A
60	4A
61	5C
62	4B
63	3A
64	2A
65	1A
66	2B
67	3B
68	1C
69	1B
70	3D
71	3C
72	1D

ORDER	Pin ID
73	2C
74	3E
75	2D
76	2E
77	1E
78	2F
79	3F
80	1G
81	1F
82	3G
83	2G
84	1H
85	1J
86	2J
87	3K
88	3J
89	2K
90	1K
91	2L
92	3L
93	1M
94	1L
95	3N
96	3M
97	1N
98	2M
99	3P
100	2N
101	2P
102	1P
103	3R
104	4R
105	4P
106	5P
107	5N
108	5R
109	Internal

Notes:

1. NC pins as defined on the **FBGA Ball Assignments** are read as "don't cares".
2. State of internal pin (#109) is loaded via JTAG

IS61DDP2B41M18A/A1/A2 IS61DDP2B451236A/A1/A2



Ordering Information

Commercial Range: 0°C to +70°C

Speed	Order Part No.	Organization	Package
550 MHz	IS61DDP2B451236A-550M3	512Kx36	165 FBGA (15x17 mm)
	IS61DDP2B451236A-550M3L	512Kx36	165 FBGA (15x17 mm), lead free
	IS61DDP2B41M18A-550M3	1Mx18	165 FBGA (15x17 mm)
	IS61DDP2B41M18A-550M3L	1Mx18	166 FBGA (15x17 mm), lead free
500 MHz	IS61DDP2B451236A-500M3	512Kx36	165 FBGA (15x17 mm)
	IS61DDP2B451236A-500M3L	512Kx36	165 FBGA (15x17 mm), lead free
	IS61DDP2B41M18A-500M3	1Mx18	165 FBGA (15x17 mm)
	IS61DDP2B41M18A-500M3L	1Mx18	165 FBGA (15x17 mm), lead free
450 MHz	IS61DDP2B451236A-450M3	512Kx36	165 FBGA (15x17 mm)
	IS61DDP2B451236A-450M3L	512Kx36	165 FBGA (15x17 mm), lead free
	IS61DDP2B41M18A-450M3	1Mx18	165 FBGA (15x17 mm)
	IS61DDP2B41M18A-450M3L	1Mx18	165 FBGA (15x17 mm), lead free
400 MHz	IS61DDP2B451236A-400M3	512Kx36	165 FBGA (15x17 mm)
	IS61DDP2B451236A-400M3L	512Kx36	165 FBGA (15x17 mm), lead free
	IS61DDP2B41M18A-400M3	1Mx18	165 FBGA (15x17 mm)
	IS61DDP2B41M18A-400M3L	1Mx18	165 FBGA (15x17 mm), lead free

Commercial Range: °C to +70°C

Speed	Order Part No.	Organization	Package
550 MHz	IS61DDP2B451236A-550B4	512Kx36	165 FBGA (13x15 mm)
	IS61DDP2B451236A-550B4L	512Kx36	165 FBGA (13x15 mm), lead free
	IS61DDP2B41M18A-550B4	1Mx18	165 FBGA (13x15 mm)
	IS61DDP2B41M18A-550B4L	1Mx18	166 FBGA (13x15 mm), lead free
500 MHz	IS61DDP2B451236A-500B4	512Kx36	165 FBGA (13x15 mm)
	IS61DDP2B451236A-500B4L	512Kx36	165 FBGA (13x15 mm), lead free
	IS61DDP2B41M18A-500B4	1Mx18	165 FBGA (13x15 mm)
	IS61DDP2B41M18A-500B4L	1Mx18	165 FBGA (13x15 mm), lead free
450 MHz	IS61DDP2B451236A-450B4	512Kx36	165 FBGA (13x15 mm)
	IS61DDP2B451236A-450B4L	512Kx36	165 FBGA (13x15 mm), lead free
	IS61DDP2B41M18A-450B4	1Mx18	165 FBGA (13x15 mm)
	IS61DDP2B41M18A-450B4L	1Mx18	165 FBGA (13x15 mm), lead free
400 MHz	IS61DDP2B451236A-400B4	512Kx36	165 FBGA (13x15 mm)
	IS61DDP2B451236A-400B4L	512Kx36	165 FBGA (13x15 mm), lead free
	IS61DDP2B41M18A-400B4	1Mx18	165 FBGA (13x15 mm)
	IS61DDP2B41M18A-400B4L	1Mx18	165 FBGA (13x15 mm), lead free

IS61DDP2B41M18A/A1/A2 IS61DDP2B451236A/A1/A2



Industrial Range: -40°C to +85°C

Speed	Order Part No.	Organization	Package
550 MHz	IS61DDP2B451236A-550M3I	512Kx36	165 FBGA (15x17 mm)
	IS61DDP2B451236A-550M3LI	512Kx36	165 FBGA (15x17 mm), lead free
	IS61DDP2B41M18A-550M3I	1Mx18	165 FBGA (15x17 mm)
	IS61DDP2B41M18A-550M3LI	1Mx18	166 FBGA (15x17 mm), lead free
500 MHz	IS61DDP2B451236A-500M3I	512Kx36	165 FBGA (15x17 mm)
	IS61DDP2B451236A-500M3LI	512Kx36	165 FBGA (15x17 mm), lead free
	IS61DDP2B41M18A-500M3I	1Mx18	165 FBGA (15x17 mm)
	IS61DDP2B41M18A-500M3LI	1Mx18	165 FBGA (15x17 mm), lead free
450 MHz	IS61DDP2B451236A-450M3I	512Kx36	165 FBGA (15x17 mm)
	IS61DDP2B451236A-450M3LI	512Kx36	165 FBGA (15x17 mm), lead free
	IS61DDP2B41M18A-450M3I	1Mx18	165 FBGA (15x17 mm)
	IS61DDP2B41M18A-450M3LI	1Mx18	165 FBGA (15x17 mm), lead free
400 MHz	IS61DDP2B451236A-400M3I	512Kx36	165 FBGA (15x17 mm)
	IS61DDP2B451236A-400M3LI	512Kx36	165 FBGA (15x17 mm), lead free
	IS61DDP2B41M18A-400M3I	1Mx18	165 FBGA (15x17 mm)
	IS61DDP2B41M18A-400M3LI	1Mx18	165 FBGA (15x17 mm), lead free

Industrial Range: -40°C to +85°C

Speed	Order Part No.	Organization	Package
550 MHz	IS61DDP2B451236A-550B4I	512Kx36	165 FBGA (13x15 mm)
	IS61DDP2B451236A-550B4LI	512Kx36	165 FBGA (13x15 mm), lead free
	IS61DDP2B41M18A-550B4I	1Mx18	165 FBGA (13x15 mm)
	IS61DDP2B41M18A-550B4LI	1Mx18	166 FBGA (13x15 mm), lead free
500 MHz	IS61DDP2B451236A-500B4I	512Kx36	165 FBGA (13x15 mm)
	IS61DDP2B451236A-500B4LI	512Kx36	165 FBGA (13x15 mm), lead free
	IS61DDP2B41M18A-500B4I	1Mx18	165 FBGA (13x15 mm)
	IS61DDP2B41M18A-500B4LI	1Mx18	165 FBGA (13x15 mm), lead free
450 MHz	IS61DDP2B451236A-450B4I	512Kx36	165 FBGA (13x15 mm)
	IS61DDP2B451236A-450B4LI	512Kx36	165 FBGA (13x15 mm), lead free
	IS61DDP2B41M18A-450B4I	1Mx18	165 FBGA (13x15 mm)
	IS61DDP2B41M18A-450B4LI	1Mx18	165 FBGA (13x15 mm), lead free
400 MHz	IS61DDP2B451236A-400B4I	512Kx36	165 FBGA (13x15 mm)
	IS61DDP2B451236A-400B4LI	512Kx36	165 FBGA (13x15 mm), lead free
	IS61DDP2B41M18A-400B4I	1Mx18	165 FBGA (13x15 mm)
	IS61DDP2B41M18A-400B4LI	1Mx18	165 FBGA (13x15 mm), lead free

IS61DDP2B41M18A/A1/A2 IS61DDP2B451236A/A1/A2



Package drawing – 15x17x1.4 BGA

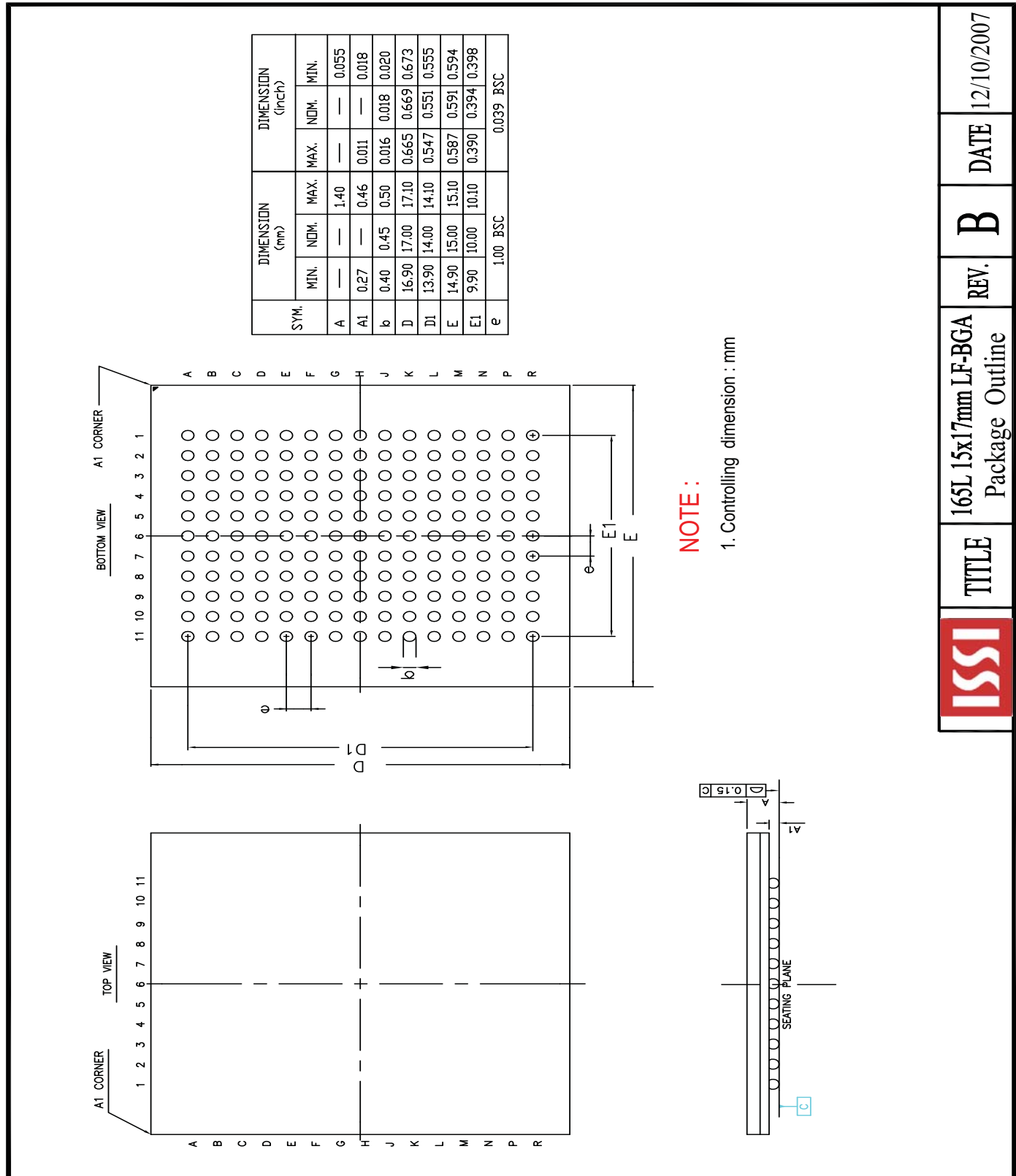

	TITLE	165L 15x17mm LF-BGA Package Outline	REV. B	DATE 12/10/2007
--	-------	--	--------	-----------------

IS61DDP2B41M18A/A1/A2 IS61DDP2B451236A/A1/A2



Package drawing – 13x15x1.4 BGA

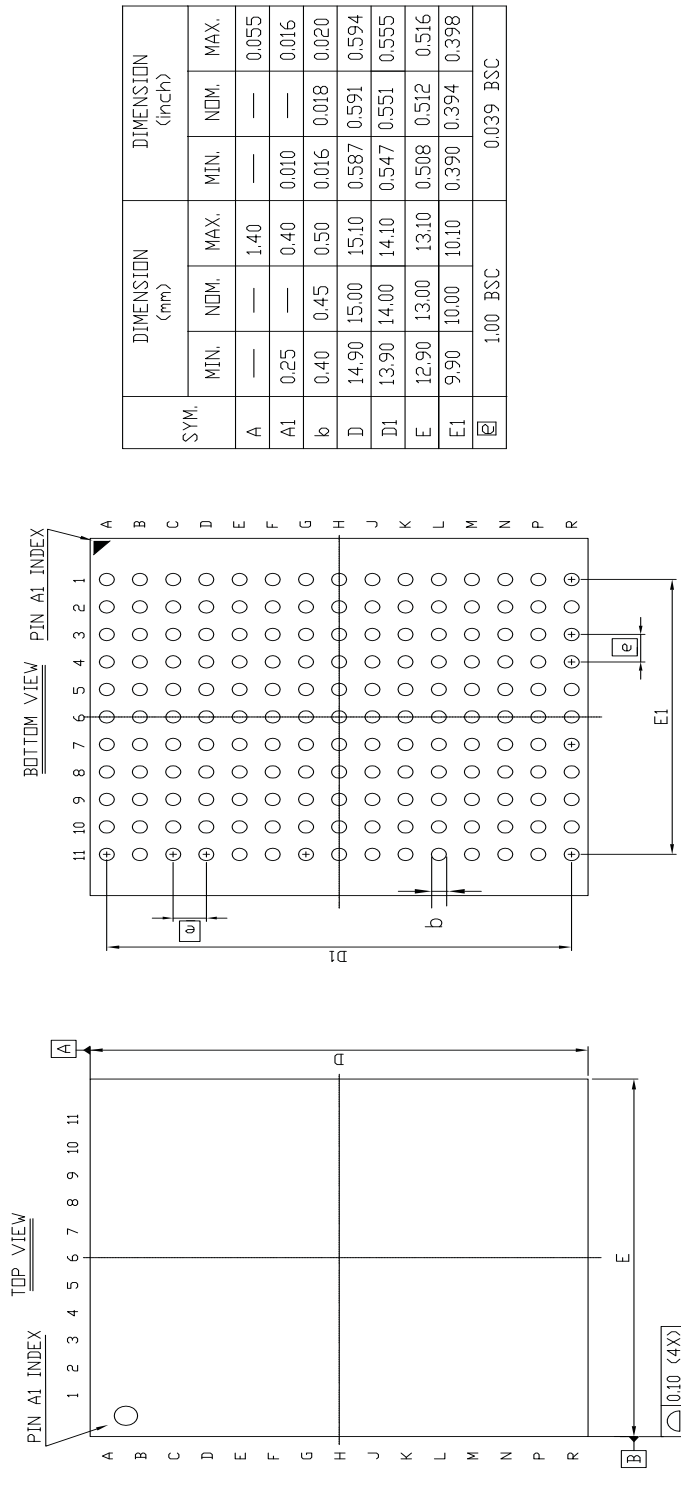

SYM.	DIMENSION (mm)			DIMENSION (inch)		
	MIN.	NOM.	MAX.	MIN.	NOM.	MAX.
A	—	—	1.40	—	—	0.055
A1	0.25	—	0.40	0.010	—	0.016
b	0.40	0.45	0.50	0.016	0.018	0.020
D	14.90	15.00	15.10	0.587	0.591	0.594
D1	13.90	14.00	14.10	0.547	0.551	0.555
E	12.90	13.00	13.10	0.508	0.512	0.516
E1	9.90	10.00	10.10	0.390	0.394	0.398
$\text{\textcircled{E}}$	1.00 BSC			0.039 BSC		

NOTE :
1. CONTROLLING DIMENSION : MM .

	TITLE	REV.	DATE
	165L 13x15x1.4mm LF-BGA Package Outline	A	11/29/2011