

## 128K x 8 HIGH-SPEED CMOS STATIC RAM

PRELIMINARY INFORMATION  
 FEBRUARY 2010

### FEATURES

#### HIGH SPEED: (IS63/64WV1288DALL/DBLL)

- High-speed access time: 8, 10, 12, 20 ns
- Low Active Power: 135 mW (typical)
- Low Standby Power: 12  $\mu$ W (typical)  
CMOS standby

#### LOW POWER: (IS63/64WV1288DALS/DBLS)

- High-speed access time: 25, 35 ns
- Low Active Power: 55 mW (typical)
- Low Standby Power: 12  $\mu$ W (typical)  
CMOS standby
- Single power supply
  - $V_{DD}$  1.65V to 2.2V (IS63WV1288DAxx)
  - $V_{DD}$  2.4V to 3.6V (IS63/64WV1288DBxx)
- Multiple center power and ground pins for greater noise immunity
- Easy memory expansion with  $\overline{CE}$  and  $\overline{OE}$  options
- $\overline{CE}$  power-down
- Fully static operation: no clock or refresh required
- TTL compatible inputs and outputs
- Lead-free available

### DESCRIPTION

The *ISSI* IS63/64WV1288Dxxx is a very high-speed, low power, 131,072-word by 8-bit CMOS static RAM. The IS63/64WV1288DBLL is fabricated using *ISSI*'s high-performance CMOS technology. This highly reliable process coupled with innovative circuit design techniques, yields higher performance and low power consumption devices.

When  $\overline{CE}$  is HIGH (deselected), the device assumes a standby mode at which the power dissipation can be reduced down to 25  $\mu$ W (typical) with CMOS input levels.

The IS63/64WV1288DBLL operates from a single  $V_{DD}$  power supply. The IS63/64WV1288Dxxx is available in 32-pin TSOP (Type II), 32-pin sTSOP (Type I), 48-Ball miniBGA (6mm x 8mm), and 32-pin SOJ (300-mil) packages.

### FUNCTIONAL BLOCK DIAGRAM

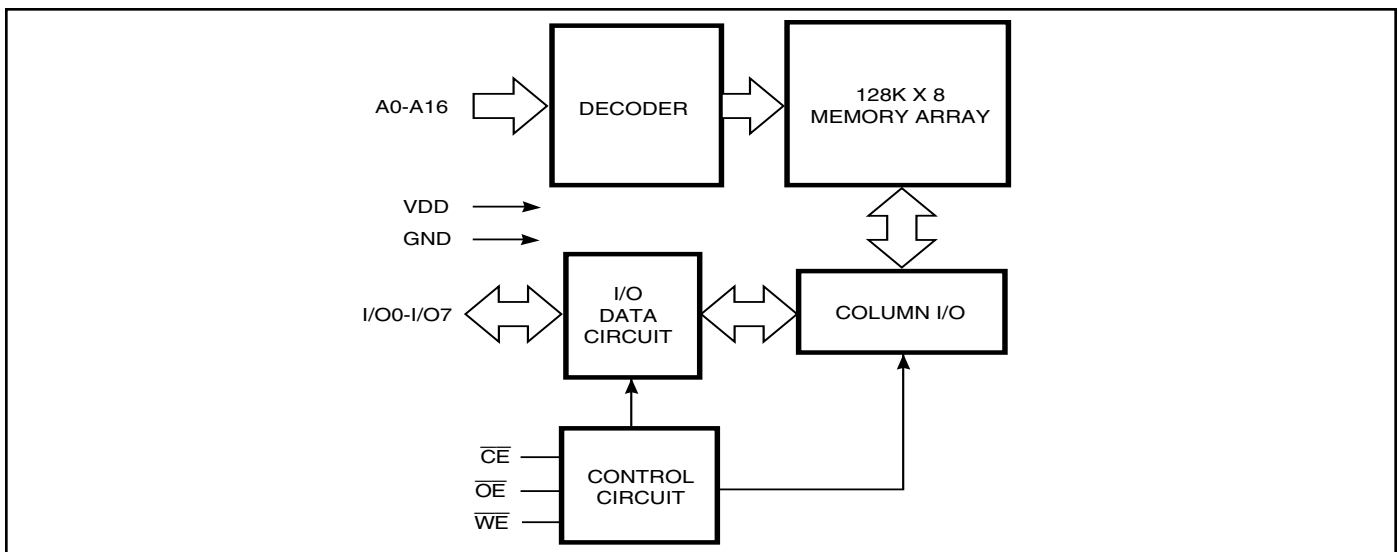

Copyright © 2010 Integrated Silicon Solution, Inc. All rights reserved. ISSI reserves the right to make changes to this specification and its products at any time without notice. ISSI assumes no liability arising out of the application or use of any information, products or services described herein. Customers are advised to obtain the latest version of this device specification before relying on any published information and before placing orders for products.

### PIN CONFIGURATION

#### 32-Pin SOJ

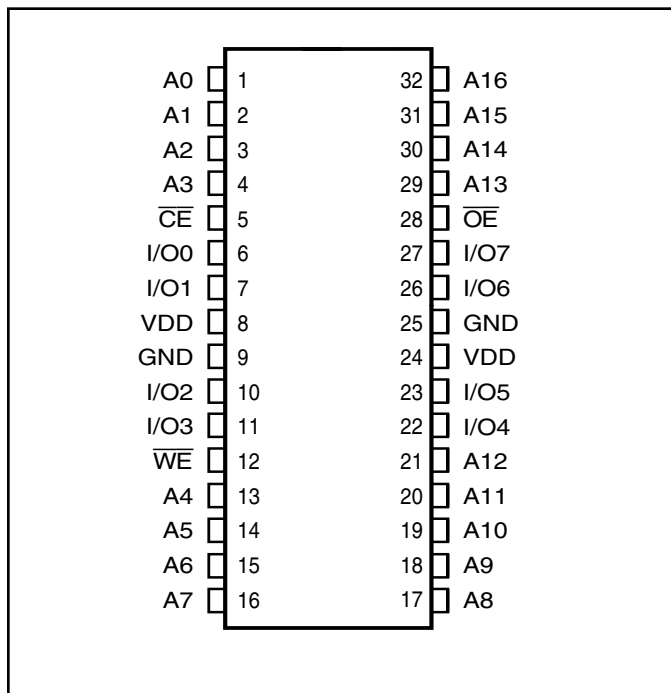

### PIN CONFIGURATION

#### 32-Pin TSOP (Type II) (T) 32-Pin sTSOP (Type I) (H)

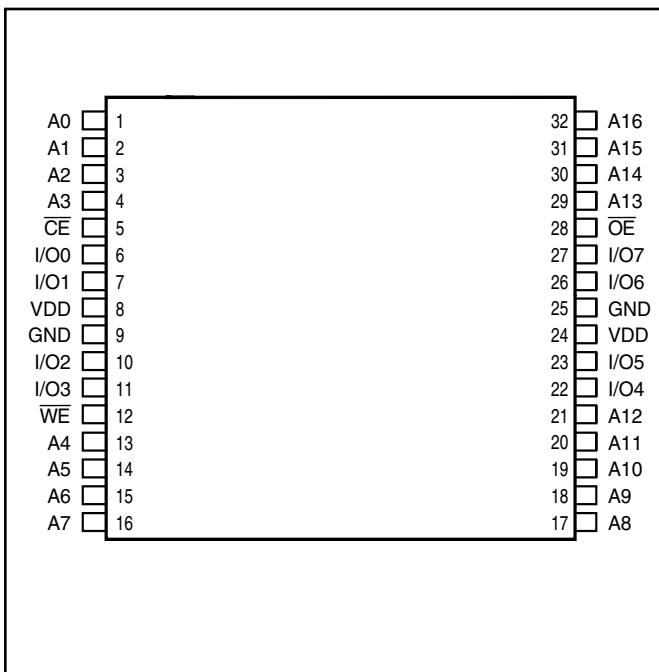

### PIN DESCRIPTIONS

A0-A16	Address Inputs
CE	Chip Enable Input
OE	Output Enable Input
WE	Write Enable Input
I/O0-I/O7	Bidirectional Ports
VDD	Power
GND	Ground

### PIN CONFIGURATION

#### 48-mini BGA (B) (6 mm x 8 mm)

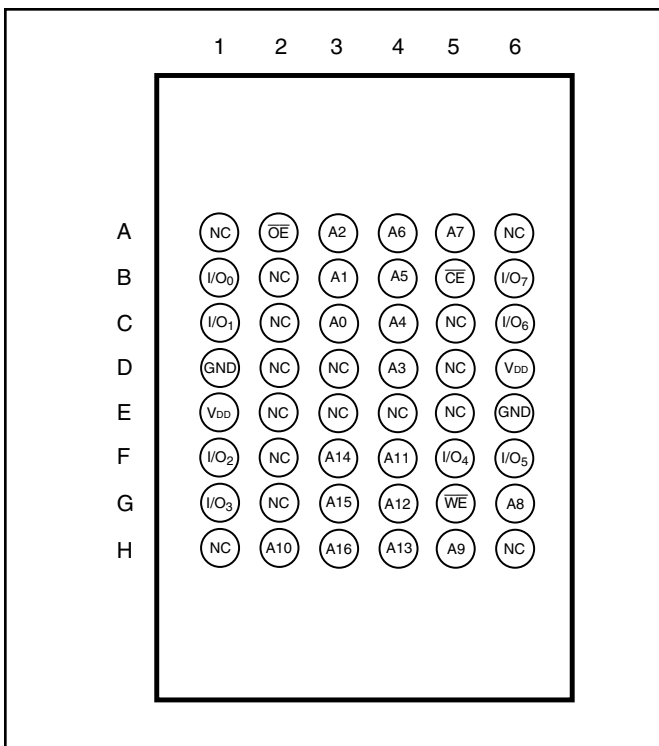

## TRUTH TABLE

Mode	$\overline{WE}$	$\overline{CE}$	$\overline{OE}$	I/O Operation	V <sub>DD</sub> Current
Not Selected (Power-down)	X	H	X	High-Z	I <sub>SB1</sub> , I <sub>SB2</sub>
Output Disabled	H	L	H	High-Z	I <sub>CC1</sub> , I <sub>CC2</sub>
Read	H	L	L	D <sub>OUT</sub>	I <sub>CC1</sub> , I <sub>CC2</sub>
Write	L	L	X	D <sub>IN</sub>	I <sub>CC1</sub> , I <sub>CC2</sub>

## ABSOLUTE MAXIMUM RATINGS<sup>(1)</sup>

Symbol	Parameter	Value	Unit
V <sub>TERM</sub>	Terminal Voltage with Respect to GND	-0.5 to V <sub>DD</sub> +0.5	V
T <sub>STG</sub>	Storage Temperature	-65 to +150	°C
P <sub>T</sub>	Power Dissipation	1.5	W
V <sub>DD</sub>	V <sub>DD</sub> Related to GND	-0.2 to +3.9	V

**Note:**

1. Stress greater than those listed under ABSOLUTE MAXIMUM RATINGS may cause permanent damage to the device. This is a stress rating only and functional operation of the device at these or any other conditions above those indicated in the operational sections of this specification is not implied. Exposure to absolute maximum rating conditions for extended periods may affect reliability.

## AC TEST CONDITIONS

Parameter	Unit (2.4V-3.6V)	Unit (3.3V ± 5%)	Unit (1.65V-2.2V)
Input Pulse Level	0.4V to $V_{DD} - 0.3V$	0.4V to $V_{DD} - 0.3V$	0.4V to $V_{DD} - 0.3V$
Input Rise and Fall Times	1V/ ns	1V/ ns	1V/ ns
Input and Output Timing and Reference Level ( $V_{Ref}$ )	$V_{DD} / 2$	$\frac{V_{DD} + 0.05}{2}$	0.9V
Output Load	See Figures 1 and 2	See Figures 1 and 2	See Figures 1 and 2
R1 ( $\Omega$ )	1909	317	13500
R2 ( $\Omega$ )	1105	351	10800
$V_{TM}$ (V)	3.0V	3.3V	1.8V

## AC TEST LOADS

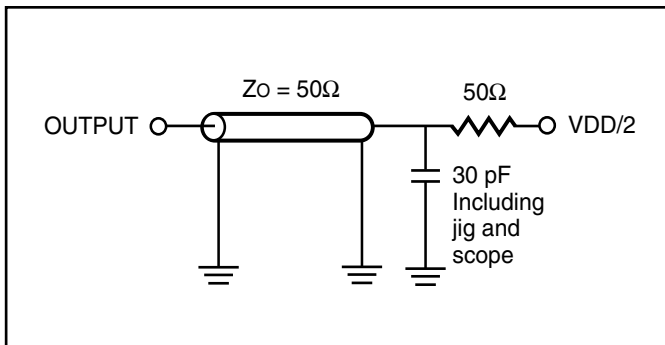

Figure 1.

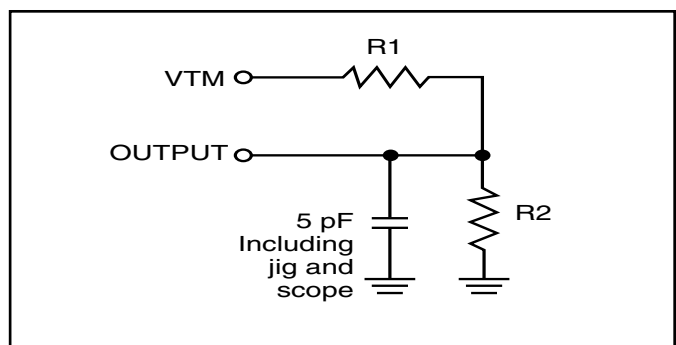

Figure 2.

### DC ELECTRICAL CHARACTERISTICS (Over Operating Range)

$V_{DD} = 3.3V \pm 5\%$

Symbol	Parameter	Test Conditions	Min.	Max.	Unit
$V_{OH}$	Output HIGH Voltage	$V_{DD} = \text{Min.}, I_{OH} = -4.0 \text{ mA}$	2.4	—	V
$V_{OL}$	Output LOW Voltage	$V_{DD} = \text{Min.}, I_{OL} = 8.0 \text{ mA}$	—	0.4	V
$V_{IH}$	Input HIGH Voltage		2	$V_{DD} + 0.3$	V
$V_{IL}$	Input LOW Voltage <sup>(1)</sup>		-0.3	0.8	V
$I_{LI}$	Input Leakage	$GND \leq V_{IN} \leq V_{DD}$	-1	1	$\mu\text{A}$
$I_{LO}$	Output Leakage	$GND \leq V_{OUT} \leq V_{DD}$ , Outputs Disabled	-1	1	$\mu\text{A}$

**Note:**

- $V_{IL} (\text{min.}) = -0.3V \text{ DC}; V_{IL} (\text{min.}) = -2.0V \text{ AC}$  (pulse width < 10 ns). Not 100% tested.  
 $V_{IH} (\text{max.}) = V_{DD} + 0.3V \text{ DC}; V_{IH} (\text{max.}) = V_{DD} + 2.0V \text{ AC}$  (pulse width < 10 ns). Not 100% tested.

### DC ELECTRICAL CHARACTERISTICS (Over Operating Range)

$V_{DD} = 2.4V-3.6V$

Symbol	Parameter	Test Conditions	Min.	Max.	Unit
$V_{OH}$	Output HIGH Voltage	$V_{DD} = \text{Min.}, I_{OH} = -1.0 \text{ mA}$	1.8	—	V
$V_{OL}$	Output LOW Voltage	$V_{DD} = \text{Min.}, I_{OL} = 1.0 \text{ mA}$	—	0.4	V
$V_{IH}$	Input HIGH Voltage		2.0	$V_{DD} + 0.3$	V
$V_{IL}$	Input LOW Voltage <sup>(1)</sup>		-0.3	0.8	V
$I_{LI}$	Input Leakage	$GND \leq V_{IN} \leq V_{DD}$	-1	1	$\mu\text{A}$
$I_{LO}$	Output Leakage	$GND \leq V_{OUT} \leq V_{DD}$ , Outputs Disabled	-1	1	$\mu\text{A}$

**Note:**

- $V_{IL} (\text{min.}) = -0.3V \text{ DC}; V_{IL} (\text{min.}) = -2.0V \text{ AC}$  (pulse width < 10 ns). Not 100% tested.  
 $V_{IH} (\text{max.}) = V_{DD} + 0.3V \text{ DC}; V_{IH} (\text{max.}) = V_{DD} + 2.0V \text{ AC}$  (pulse width < 10 ns). Not 100% tested.

### DC ELECTRICAL CHARACTERISTICS (Over Operating Range)

$V_{DD} = 1.65V-2.2V$

Symbol	Parameter	Test Conditions	$V_{DD}$	Min.	Max.	Unit
$V_{OH}$	Output HIGH Voltage	$I_{OH} = -0.1 \text{ mA}$	1.65-2.2V	1.4	—	V
$V_{OL}$	Output LOW Voltage	$I_{OL} = 0.1 \text{ mA}$	1.65-2.2V	—	0.2	V
$V_{IH}$	Input HIGH Voltage		1.65-2.2V	1.4	$V_{DD} + 0.2$	V
$V_{IL}^{(1)}$	Input LOW Voltage		1.65-2.2V	-0.2	0.4	V
$I_{LI}$	Input Leakage	$GND \leq V_{IN} \leq V_{DD}$		-1	1	$\mu\text{A}$
$I_{LO}$	Output Leakage	$GND \leq V_{OUT} \leq V_{DD}$ , Outputs Disabled		-1	1	$\mu\text{A}$

**Note:**

- $V_{IL} (\text{min.}) = -0.3V \text{ DC}; V_{IL} (\text{min.}) = -2.0V \text{ AC}$  (pulse width < 10 ns). Not 100% tested.  
 $V_{IH} (\text{max.}) = V_{DD} + 0.3V \text{ DC}; V_{IH} (\text{max.}) = V_{DD} + 2.0V \text{ AC}$  (pulse width < 10 ns). Not 100% tested.

## HIGH SPEED (IS63WV1288DALL/DBLL)

### OPERATING RANGE (V<sub>DD</sub>) (IS63WV1288DALL)

Range	Ambient Temperature	V <sub>DD</sub>	Speed
Commercial	0°C to +70°C	1.65V-2.2V	20ns
Industrial	-40°C to +85°C	1.65V-2.2V	20ns
Automotive	-40°C to +125°C	1.65V-2.2V	20ns

### OPERATING RANGE (V<sub>DD</sub>) (IS63WV1288DBLL)<sup>(1)</sup>

Range	Ambient Temperature	V <sub>DD</sub> (8 ns) <sup>1</sup>	V <sub>DD</sub> (10 ns) <sup>1</sup>
Commercial	0°C to +70°C	3.3V ± 5%	2.4V-3.6V
Industrial	-40°C to +85°C	3.3V ± 5%	2.4V-3.6V

**Note:**

- When operated in the range of 2.4V-3.6V, the device meets 10ns. When operated in the range of 3.3V ± 5%, the device meets 8ns.

### OPERATING RANGE (V<sub>DD</sub>) (IS64WV1288DBLL)<sup>(2)</sup>

Range	Ambient Temperature	V <sub>DD</sub> (8 ns) <sup>2</sup>	V <sub>DD</sub> (10 ns) <sup>2</sup>
Automotive	-40°C to +125°C	3.3V ± 5%	2.4V-3.6V

**Note:**

- When operated in the range of 2.4V-3.6V, the device meets 10ns. When operated in the range of 3.3V ± 5%, the device meets 8ns.

## POWER SUPPLY CHARACTERISTICS<sup>(1)</sup> (Over Operating Range)

Symbol	Parameter	Test Conditions		-8		-10		-12		-20		Unit
				Min.	Max.	Min.	Max.	Min.	Max.	Min.	Max.	
I <sub>CC</sub>	V <sub>DD</sub> Dynamic Operating Supply Current	V <sub>DD</sub> = Max., I <sub>OUT</sub> = 0 mA, f = f <sub>MAX</sub> CE = V <sub>IL</sub> V <sub>IN</sub> ≥ V <sub>DD</sub> - 0.3V, or V <sub>IN</sub> ≤ 0.4V	Com.	—	65	—	50	—	45	—	40	mA
			Ind.	—	70	—	55	—	50	—	45	
			Auto. <sup>(3)</sup>	—	—	—	65	—	55	—	50	
			typ. <sup>(2)</sup>			45		45				
I <sub>SB2</sub>	CMOS Standby Current (CMOS Inputs)	V <sub>DD</sub> = Max., CE ≥ V <sub>DD</sub> - 0.2V, V <sub>IN</sub> ≥ V <sub>DD</sub> - 0.2V, or V <sub>IN</sub> ≤ 0.2V, f = 0	Com.	—	40	—	40	—	40	—	40	μA
			Ind.	—	55	—	55	—	55	—	55	
			Auto.	—	—	—	90	—	90	—	90	
			typ. <sup>(2)</sup>			4		4				

**Note:**

- At f = f<sub>MAX</sub>, address and data inputs are cycling at the maximum frequency, f = 0 means no input lines change.
- Typical values are measured at V<sub>DD</sub> = 3.0V, T<sub>A</sub> = 25°C and not 100% tested.
- For Automotive grade at 15ns, typ. I<sub>CC</sub> = 38mA, not 100% tested.

## LOW POWER (IS63WV1288DALS/DBLS)

### OPERATING RANGE ( $V_{DD}$ ) (IS63WV1288DALS)

Range	Ambient Temperature	$V_{DD}$	Speed
Commercial	0°C to +70°C	1.65V-2.2V	45ns
Industrial	-40°C to +85°C	1.65V-2.2V	45ns
Automotive	-40°C to +125°C	1.65V-2.2V	55ns

### OPERATING RANGE ( $V_{DD}$ ) (IS63WV1288DBLS)

Range	Ambient Temperature	$V_{DD}$ (35 ns)
Commercial	0°C to +70°C	2.4V-3.6V
Industrial	-40°C to +85°C	2.4V-3.6V

### OPERATING RANGE ( $V_{DD}$ ) (IS64WV1288DBLS)

Range	Ambient Temperature	$V_{DD}$ (35 ns)
Automotive	-40°C to +125°C	2.4V-3.6V

### POWER SUPPLY CHARACTERISTICS<sup>(1)</sup> (Over Operating Range)

Symbol	Parameter	Test Conditions		-25		-35		-45		Unit
				Min.	Max.	Min.	Max.	Min.	Max.	
I <sub>CC</sub>	V <sub>DD</sub> Dynamic Operating Supply Current	V <sub>DD</sub> = Max., I <sub>OUT</sub> = 0 mA, f = f <sub>MAX</sub> CE = V <sub>IL</sub> V <sub>IN</sub> ≥ V <sub>DD</sub> - 0.3V, or V <sub>IN</sub> ≤ 0.4V	Com.	—	15	—	15	—	12	mA
			Ind.	—	20	—	20	—	18	
			Auto.	—	30	—	30	—	25	
			typ. <sup>(2)</sup>	18						
I <sub>SB2</sub>	CMOS Standby Current (CMOS Inputs)	V <sub>DD</sub> = Max., CE ≥ V <sub>DD</sub> - 0.2V, V <sub>IN</sub> ≥ V <sub>DD</sub> - 0.2V, or V <sub>IN</sub> ≤ 0.2V, f = 0	Com.	—	40	—	40	—	40	μA
			Ind.	—	50	—	50	—	50	
			Auto.	—	75	—	75	—	75	
			typ. <sup>(2)</sup>	4						

**Note:**

- At f = f<sub>MAX</sub>, address and data inputs are cycling at the maximum frequency, f = 0 means no input lines change.
- Typical values are measured at V<sub>DD</sub> = 3.0V, T<sub>A</sub> = 25°C and not 100% tested.

### READ CYCLE SWITCHING CHARACTERISTICS<sup>(1)</sup> (Over Operating Range)

Symbol	Parameter	-8 ns		-10 ns		-12 ns		Unit
		Min.	Max.	Min.	Max.	Min.	Max.	
t <sub>RC</sub>	Read Cycle Time	8	—	10	—	12	—	ns
t <sub>AA</sub>	Address Access Time	—	8	—	10	—	12	ns
t <sub>OHA</sub>	Output Hold Time	2	—	2	—	2	—	ns
t <sub>ACE</sub>	CE Access Time	—	8	—	10	—	12	ns
t <sub>DOE</sub>	OE Access Time	—	4	—	5	—	6	ns
t <sub>LZOE</sub> <sup>(2)</sup>	OE to Low-Z Output	0	—	0	—	0	—	ns
t <sub>HZOE</sub> <sup>(2)</sup>	OE to High-Z Output	0	4	0	5	0	6	ns
t <sub>LZCE</sub> <sup>(2)</sup>	CE to Low-Z Output	3	—	3	—	3	—	ns
t <sub>HZCE</sub> <sup>(2)</sup>	CE to High-Z Output	0	4	0	5	0	6	ns
t <sub>PU</sub>	CE to Power Up Time	0	—	0	—	0	—	ns
t <sub>PD</sub>	CE to Power Down Time	—	8	—	10	—	12	ns

**Notes:**

1. Test conditions assume signal transition times of 3 ns or less, timing reference levels of 1.5V, input pulse levels of 0 to 3.0V loading specified in Figure 1.
2. Tested with the loading specified in Figure 2. Transition is measured ±500 mV from steady-state voltage. Not 100% tested.

### READ CYCLE SWITCHING CHARACTERISTICS<sup>(1)</sup> (Over Operating Range)

Symbol	Parameter	-20 ns		-25 ns		-35 ns		-45 ns		Unit
		Min.	Max.	Min.	Max.	Min.	Max.	Min.	Max.	
t <sub>RC</sub>	Read Cycle Time	20	—	25	—	35	—	45	—	ns
t <sub>AA</sub>	Address Access Time	—	20	—	25	—	35	—	45	ns
t <sub>OHA</sub>	Output Hold Time	2.5	—	6	—	8	—	10	—	ns
t <sub>ACE</sub>	CE Access Time	—	20	—	25	—	35	—	45	ns
t <sub>DOE</sub>	OE Access Time	—	8	—	12	—	15	—	20	ns
t <sub>HZOE</sub> <sup>(2)</sup>	OE to High-Z Output	0	8	0	8	0	10	0	15	ns
t <sub>LZOE</sub> <sup>(2)</sup>	OE to Low-Z Output	0	—	0	—	0	—	0	—	ns
t <sub>HZCE</sub> <sup>(2)</sup>	CE to High-Z Output	0	8	0	8	0	10	0	15	ns
t <sub>LZCE</sub> <sup>(2)</sup>	CE to Low-Z Output	3	—	10	—	10	—	10	—	ns

**Notes:**

1. Test conditions assume signal transition times of 1.5 ns or less, timing reference levels of 1.25V, input pulse levels of 0.4V to V<sub>DD</sub>-0.3V and output loading specified in Figure 1a.
2. Tested with the load in Figure 1b. Transition is measured ±500 mV from steady-state voltage. Not 100% tested.
3. Not 100% tested.

## AC WAVEFORMS

### READ CYCLE NO. 1<sup>(1,2)</sup>

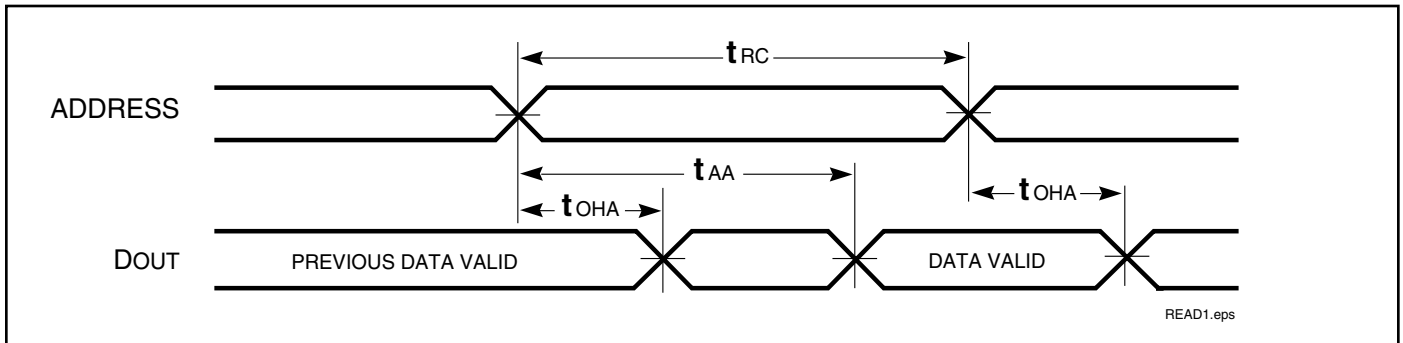

### READ CYCLE NO. 2<sup>(1,3)</sup>

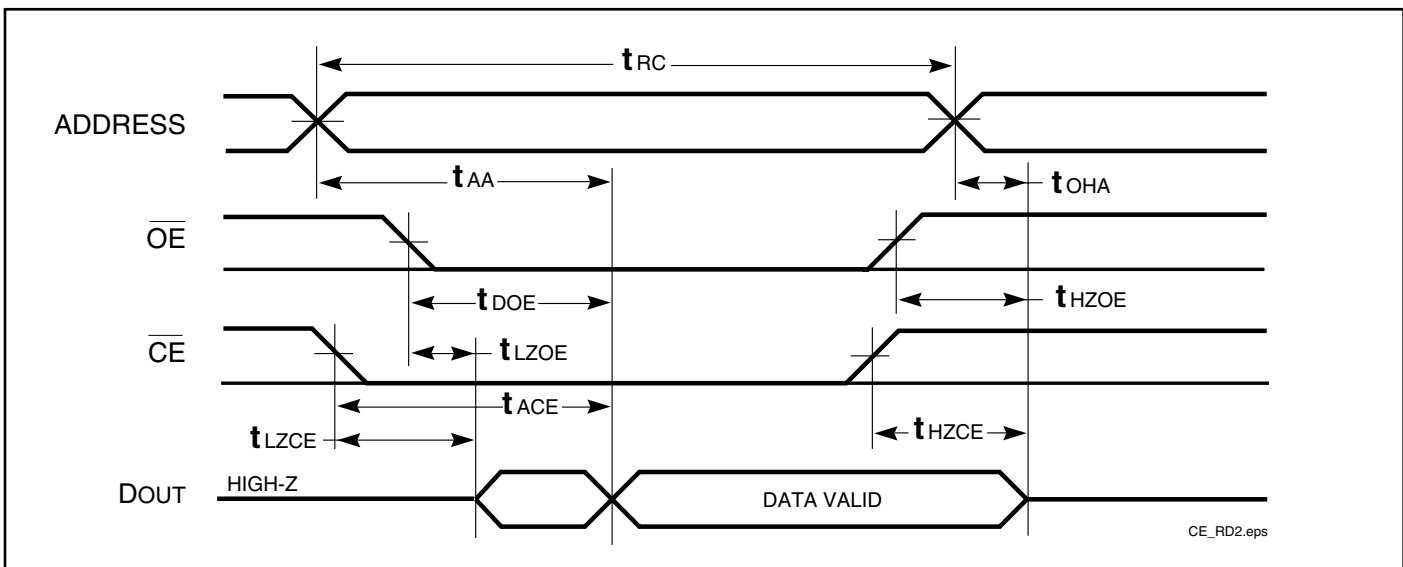

**Notes:**

1.  $\overline{WE}$  is HIGH for a Read Cycle.
2. The device is continuously selected.  $\overline{OE}$ ,  $\overline{CE} = V_{IL}$ .
3. Address is valid prior to or coincident with  $\overline{CE}$  LOW transitions.

**WRITE CYCLE SWITCHING CHARACTERISTICS<sup>(1,3)</sup>** (Over Operating Range)

Symbol	Parameter	-8 ns		-10 ns		-12 ns		Unit
		Min.	Max.	Min.	Max.	Min.	Max.	
t <sub>wc</sub>	Write Cycle Time	8	—	10	—	12	—	ns
t <sub>sce</sub>	$\overline{CE}$ to Write End	7	—	7	—	8	—	ns
t <sub>aw</sub>	Address Setup Time to Write End	8	—	8	—	8	—	ns
t <sub>ha</sub>	Address Hold from Write End	0	—	0	—	0	—	ns
t <sub>sa</sub>	Address Setup Time	0	—	0	—	0	—	ns
t <sub>pwe<sub>1</sub></sub> <sup>(1)</sup>	$\overline{WE}$ Pulse Width ( $\overline{OE}$ High)	7	—	7	—	8	—	ns
t <sub>pwe<sub>2</sub></sub> <sup>(2)</sup>	$\overline{WE}$ Pulse Width ( $\overline{OE}$ Low)	8	—	10	—	12	—	ns
t <sub>sd</sub>	Data Setup to Write End	5	—	5	—	6	—	ns
t <sub>hd</sub>	Data Hold from Write End	0	—	0	—	0	—	ns
t <sub>hzwe</sub> <sup>(2)</sup>	$\overline{WE}$ LOW to High-Z Output	—	4	—	5	—	6	ns
t <sub>lzwe</sub> <sup>(2)</sup>	$\overline{WE}$ HIGH to Low-Z Output	3	—	3	—	3	—	ns

**Notes:**

1. Test conditions assume signal transition times of 3ns or less, timing reference levels of 1.5V, input pulse levels of 0 to 3.0V and output loading specified in Figure 1.
2. Tested with the load in Figure 2. Transition is measured  $\pm 500$  mV from steady-state voltage. Not 100% tested.
3. The internal write time is defined by the overlap of  $\overline{CE}$  LOW and  $\overline{WE}$  LOW. All signals must be in valid states to initiate a Write, but any one can go inactive to terminate the Write. The Data Input Setup and Hold timing are referenced to the rising or falling edge of the signal that terminates the Write.

**WRITE CYCLE SWITCHING CHARACTERISTICS<sup>(1,2)</sup>** (Over Operating Range)

Symbol	Parameter	-20 ns		-25 ns		-35 ns		-45ns		Unit
		Min.	Max.	Min.	Max.	Min.	Max.	Min.	Max.	
t <sub>wc</sub>	Write Cycle Time	20	—	25	—	35	—	45	—	ns
t <sub>sce</sub>	$\overline{CE}$ to Write End	12	—	18	—	25	—	35	—	ns
t <sub>aw</sub>	Address Setup Time to Write End	12	—	15	—	25	—	35	—	ns
t <sub>ha</sub>	Address Hold from Write End	0	—	0	—	0	—	0	—	ns
t <sub>sa</sub>	Address Setup Time	0	—	0	—	0	—	0	—	ns
t <sub>pwe<sub>1</sub></sub>	$\overline{WE}$ Pulse Width ( $\overline{OE}$ = HIGH)	12	—	18	—	30	—	35	—	ns
t <sub>pwe<sub>2</sub></sub>	$\overline{WE}$ Pulse Width ( $\overline{OE}$ = LOW)	17	—	20	—	30	—	35	—	ns
t <sub>sd</sub>	Data Setup to Write End	9	—	12	—	15	—	20	—	ns
t <sub>hd</sub>	Data Hold from Write End	0	—	0	—	0	—	0	—	ns
t <sub>hzwe</sub> <sup>(3)</sup>	$\overline{WE}$ LOW to High-Z Output	—	9	—	12	—	20	—	20	ns
t <sub>lzwe</sub> <sup>(3)</sup>	$\overline{WE}$ HIGH to Low-Z Output	3	—	5	—	5	—	5	—	ns

**Notes:**

1. Test conditions for IS61WV6416LL assume signal transition times of 1.5ns or less, timing reference levels of 1.25V, input pulse levels of 0.4V to V<sub>DD</sub>-0.3V and output loading specified in Figure 1a.
2. Tested with the load in Figure 1b. Transition is measured  $\pm 500$  mV from steady-state voltage. Not 100% tested.
3. The internal write time is defined by the overlap of  $\overline{CE}$  LOW and  $\overline{UB}$  or  $\overline{LB}$ , and  $\overline{WE}$  LOW. All signals must be in valid states to initiate a Write, but any one can go inactive to terminate the Write. The Data Input Setup and Hold timing are referenced to the rising or falling edge of the signal that terminates the write.

## AC WAVEFORMS

### WRITE CYCLE NO. 1<sup>(1,2)</sup> ( $\overline{CE}$ Controlled, $\overline{OE}$ = HIGH or LOW)

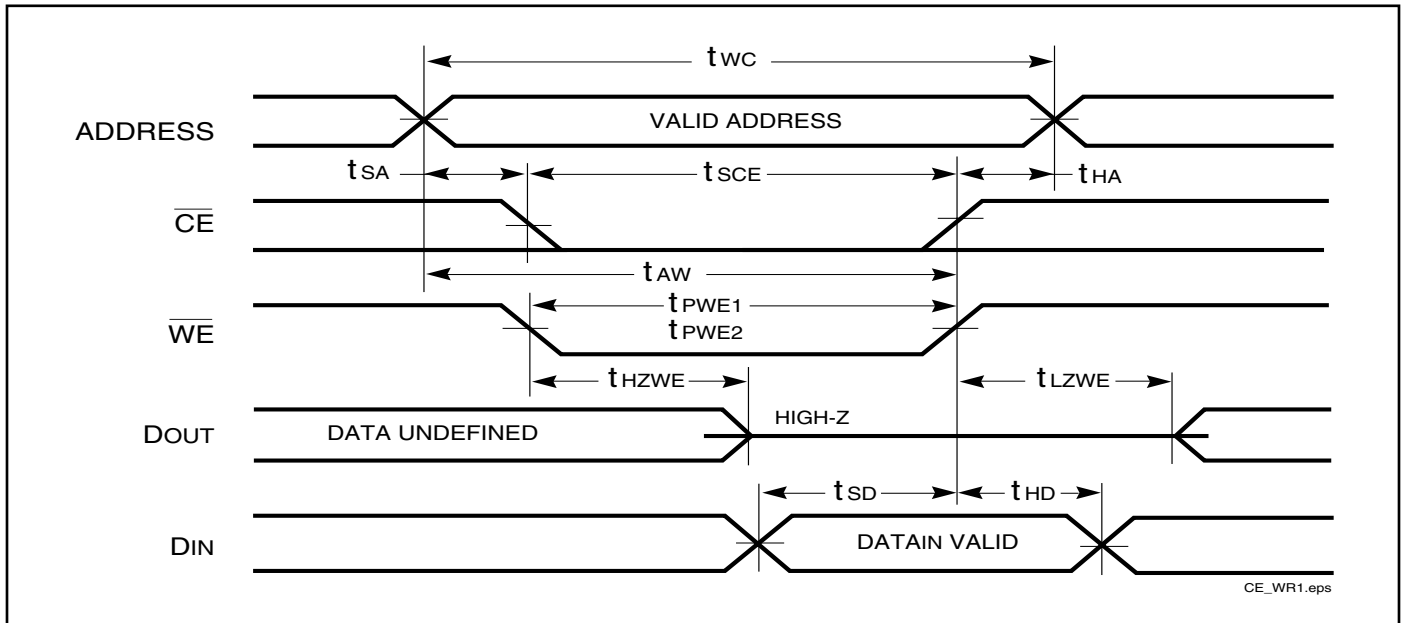

## AC WAVEFORMS

### WRITE CYCLE NO. 2<sup>(1)</sup> ( $\overline{WE}$ Controlled, $\overline{OE}$ = HIGH during Write Cycle)

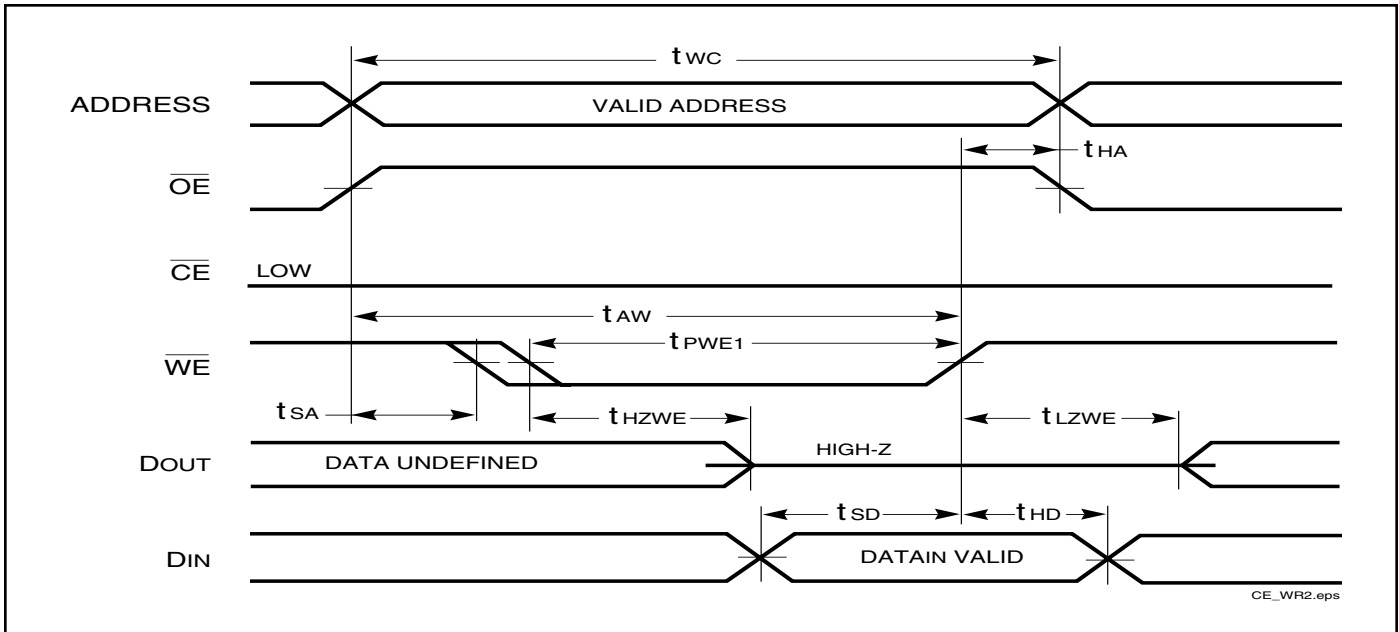

### WRITE CYCLE NO. 3 ( $\overline{WE}$ Controlled: $\overline{OE}$ is LOW During Write Cycle)

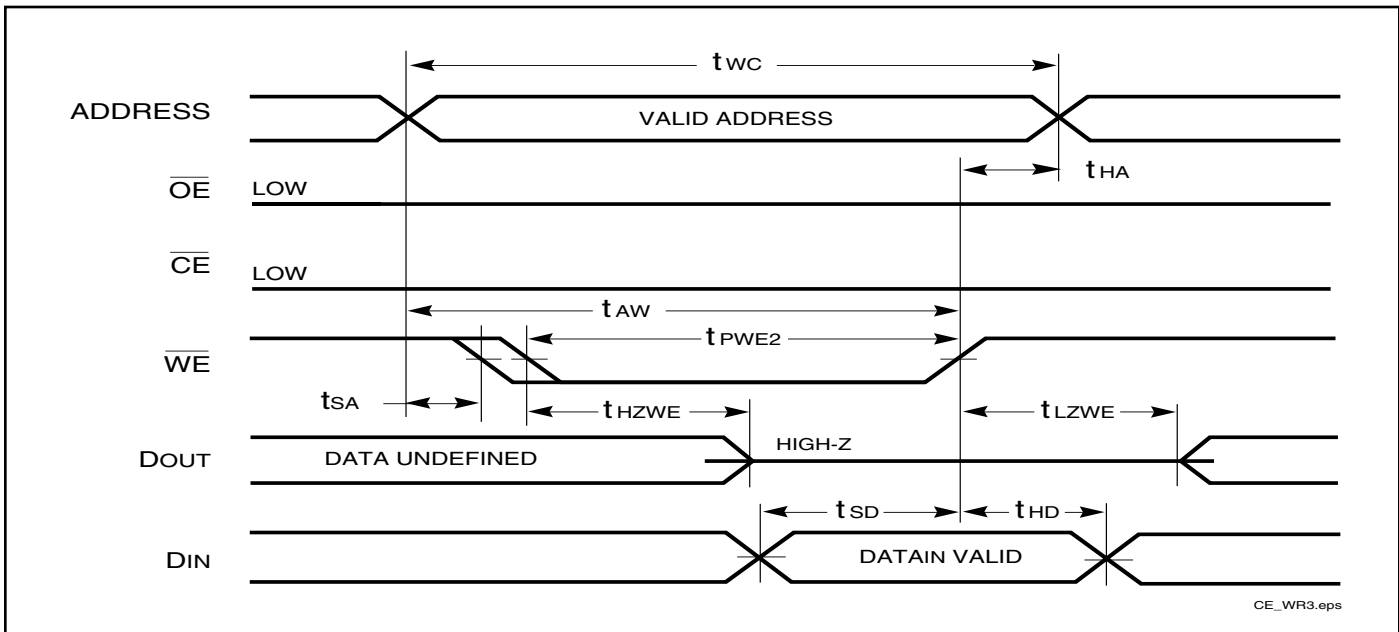

#### Notes:

1. The internal write time is defined by the overlap of  $\overline{CE}$  LOW and  $\overline{WE}$  LOW. All signals must be in valid states to initiate a Write, but any one can go inactive to terminate the Write. The Data Input Setup and Hold timing are referenced to the rising or falling edge of the signal that terminates the Write.
2. I/O will assume the High-Z state if  $\overline{OE} > V_{IH}$ .

## HIGH SPEED (IS63/4WV1288DALL/DBLL)

### DATA RETENTION SWITCHING CHARACTERISTICS (2.4V-3.6V)

Symbol	Parameter	Test Condition	Options	Min.	Typ. <sup>(1)</sup>	Max.	Unit
V <sub>DR</sub>	V <sub>DD</sub> for Data Retention	See Data Retention Waveform		2.0	—	3.6	V
I <sub>DR</sub>	Data Retention Current	V <sub>DD</sub> = 2.0V, $\overline{CE} \geq V_{DD} - 0.2V$	Com. Ind. Auto.	—	4	40 55 90	μA
t <sub>SDR</sub>	Data Retention Setup Time	See Data Retention Waveform		0	—	—	ns
t <sub>RDR</sub>	Recovery Time	See Data Retention Waveform		t <sub>RC</sub>	—	—	ns

**Note 1:** Typical values are measured at V<sub>DD</sub> = 3.0V, T<sub>A</sub> = 25°C and not 100% tested.

### DATA RETENTION SWITCHING CHARACTERISTICS (1.65V-2.2V)

Symbol	Parameter	Test Condition	Options	Min.	Typ. <sup>(1)</sup>	Max.	Unit
V <sub>DR</sub>	V <sub>DD</sub> for Data Retention	See Data Retention Waveform		1.2	—	3.6	V
I <sub>DR</sub>	Data Retention Current	V <sub>DD</sub> = 1.2V, $\overline{CE} \geq V_{DD} - 0.2V$	Com. Ind. Auto.	—	4	40 55 90	μA
t <sub>SDR</sub>	Data Retention Setup Time	See Data Retention Waveform		0	—	—	ns
t <sub>RDR</sub>	Recovery Time	See Data Retention Waveform		t <sub>RC</sub>	—	—	ns

**Note 1:** Typical values are measured at V<sub>DD</sub> = 1.8V, T<sub>A</sub> = 25°C and not 100% tested.

### DATA RETENTION WAVEFORM ( $\overline{CE}$ Controlled)

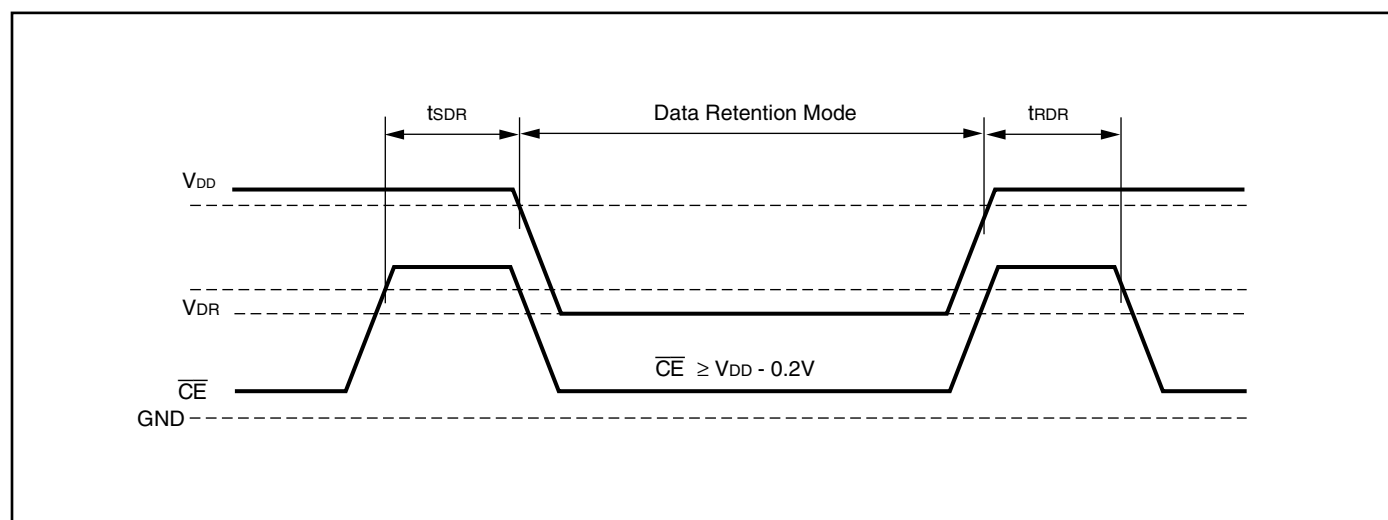

## LOW POWER (IS63/4WV1288DALS/DBLS)

### DATA RETENTION SWITCHING CHARACTERISTICS (2.4V-3.6V)

Symbol	Parameter	Test Condition	Options	Min.	Typ. <sup>(1)</sup>	Max.	Unit
V <sub>DR</sub>	V <sub>DD</sub> for Data Retention	See Data Retention Waveform		2.0	—	3.6	V
I <sub>DR</sub>	Data Retention Current	V <sub>DD</sub> = 2.0V, $\overline{CE} \geq V_{DD} - 0.2V$	Com. Ind. Auto.	—	4	40 50 75	μA
t <sub>SDR</sub>	Data Retention Setup Time	See Data Retention Waveform		0	—	—	ns
t <sub>RDR</sub>	Recovery Time	See Data Retention Waveform		t <sub>RC</sub>	—	—	ns

**Note 1:** Typical values are measured at V<sub>DD</sub> = 3.0V, T<sub>A</sub> = 25°C and not 100% tested.

### DATA RETENTION SWITCHING CHARACTERISTICS (1.65V-2.2V)

Symbol	Parameter	Test Condition	Options	Min.	Typ. <sup>(1)</sup>	Max.	Unit
V <sub>DR</sub>	V <sub>DD</sub> for Data Retention	See Data Retention Waveform		1.2	—	3.6	V
I <sub>DR</sub>	Data Retention Current	V <sub>DD</sub> = 1.2V, $\overline{CE} \geq V_{DD} - 0.2V$	Com. Ind. Auto.	—	4	40 50 75	μA
t <sub>SDR</sub>	Data Retention Setup Time	See Data Retention Waveform		0	—	—	ns
t <sub>RDR</sub>	Recovery Time	See Data Retention Waveform		t <sub>RC</sub>	—	—	ns

**Note 1:** Typical values are measured at V<sub>DD</sub> = 1.8V, T<sub>A</sub> = 25°C and not 100% tested.

### DATA RETENTION WAVEFORM ( $\overline{CE}$ Controlled)

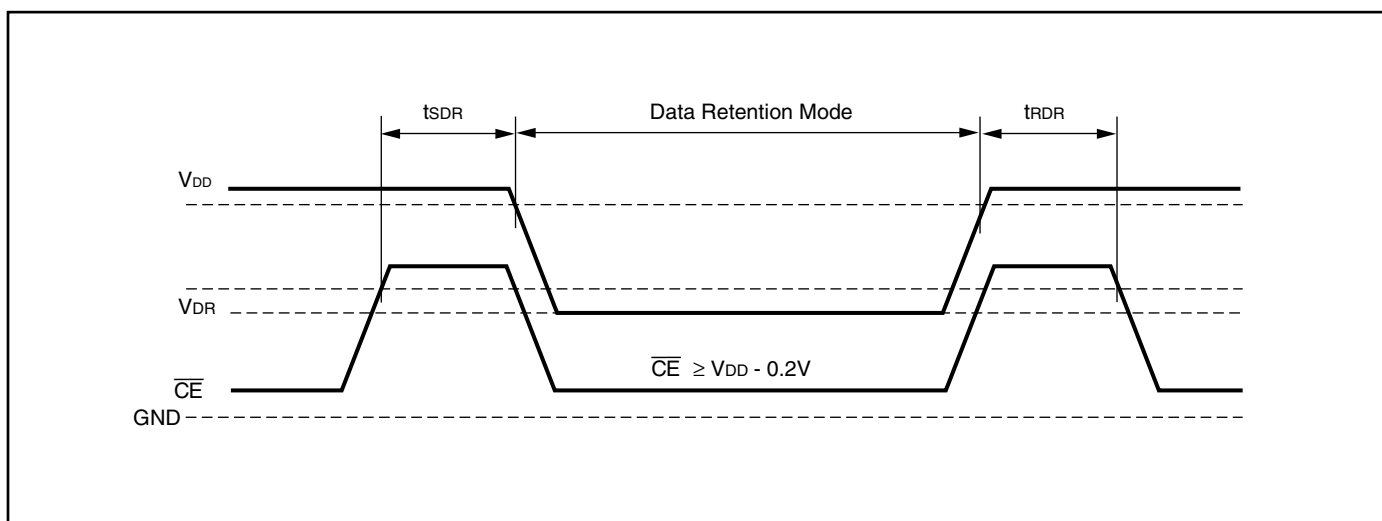

## ORDERING INFORMATION

### Industrial Range: -40°C to +85°C

Speed (ns)	Order Part No.	Package
8	IS63WV1288DBLL-8TI	32-pin TSOP (Type II)
	IS63WV1288DBLL-8TLI	32-pin TSOP (Type II), Lead-free
	IS63WV1288DBLL-8HI	sTSOP (Type I) (8mm x13.4mm)
	IS63WV1288DBLL-8HLI	sTSOP (Type I) (8mm x13.4mm), Lead-free
	IS63WV1288DBLL-8JI	32-pin SOJ (300-mil)
	IS63WV1288DBLL-8JLI	32-pin SOJ (300-mil), Lead-free
10	IS63WV1288DBLL-10TI	32-pin TSOP (Type II)
	IS63WV1288DBLL-10TLI	32-pin TSOP (Type II), Lead-free
	IS63WV1288DBLL-10HI	sTSOP (Type I) (8mm x13.4mm)
	IS63WV1288DBLL-10HLI	sTSOP (Type I) (8mm x13.4mm), Lead-free
	IS63WV1288DBLL-10JI	32-pin SOJ (300-mil)
	IS63WV1288DBLL-10JLI	32-pin SOJ (300-mil), Lead-free

### Automotive Range (A3): -40°C to +125°C

Speed (ns)	Order Part No.	Package
10(8*)	IS64WV1288DBLL-10TA3	32-pin TSOP (Type II)
	IS64WV1288DBLL-10TLA3	32-pin TSOP (Type II), Lead-free
	IS64WV1288DBLL-10HA3	sTSOP (Type I) (8mm x13.4mm)
	IS64WV1288DBLL-10HLA3	sTSOP (Type I) (8mm x13.4mm), Lead-free

**Note:**

1. Speed = 8ns for V<sub>DD</sub> = 3.3V + 5%. Speed = 10ns for V<sub>DD</sub> = 2.4V-3.6V.

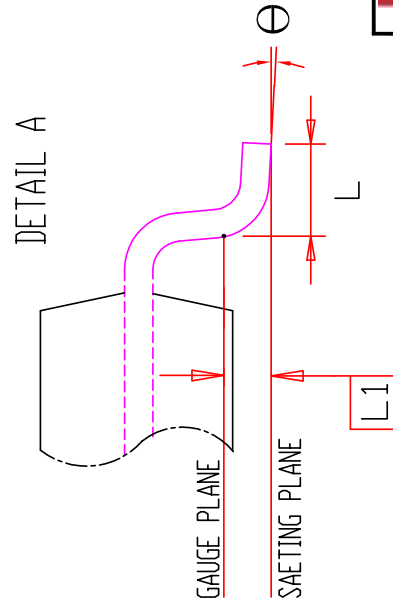
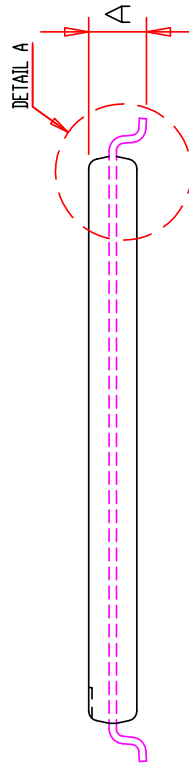
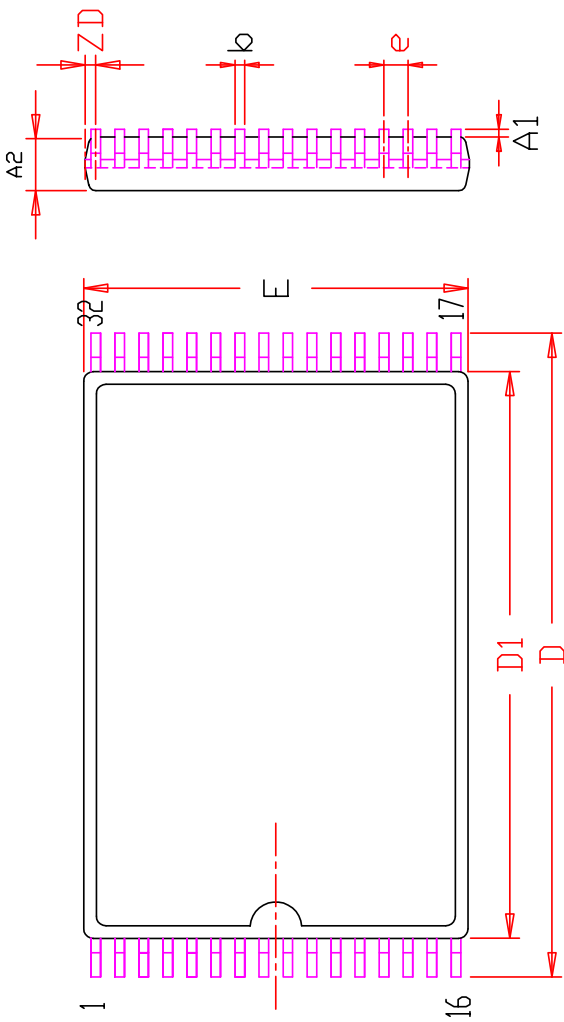

SYMBOL	DIMENSION IN MM			DIMENSION IN INCH		
	MIN	NOM	MAX	MIN	NOM	MAX
A	0.95		1.25	0.037		0.049
A1	0.05		0.15	0.002		0.008
A2	0.90		1.05	0.035		0.041
b	0.16		0.27	0.006		0.011
D	13.10	13.40	13.70	0.516	0.528	0.539
D1	11.70	11.80	11.90	0.461	0.465	0.469
E	7.90	8.00	8.10	0.311	0.315	0.319
e	0.50 BSC.			0.020 BSC.		
L	0.30	0.50	0.70	0.012	0.020	0.028
L1	0.25 BSC.			0.010 BSC.		
ZD	0.25 REF.			0.010 REF.		
Θ	0	3°	5°	0	3°	5°

**NOTE :**

1. CONTROLLING DIMENSION : MM
2. DIMENSION D1 AND E DO NOT INCLUDE MOLD PROTRUSION.
3. DIMENSION b DOES NOT INCLUDE DAMBAR PROTRUSION/INTRUSION.
4. Reference Document : JEDEC MO-183



TITLE

32L 8x13.4mm TSOP-1  
 Package Outline

REV.

E

DATE

04/24/2009

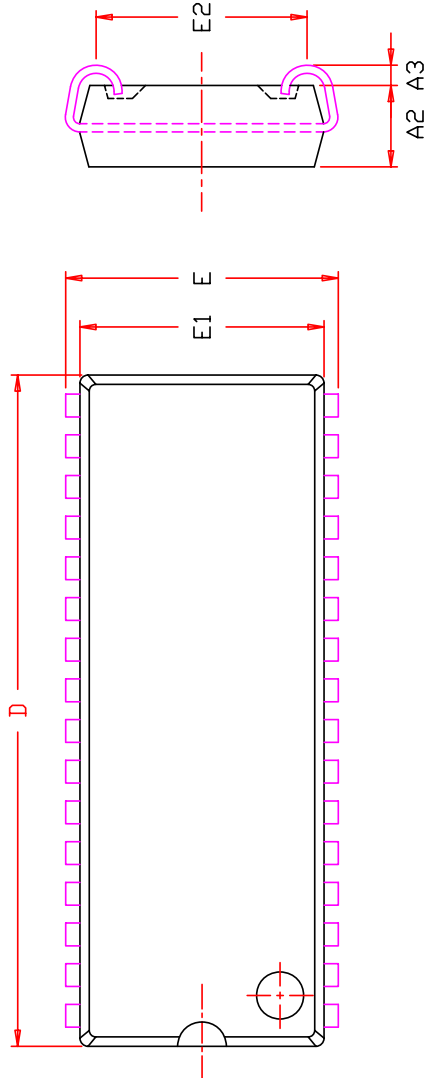

SYMBOL	DIMENSION IN MM			DIMENSION IN INCH		
	MIN.	NOM.	MAX.	MIN.	NOM.	MAX.
A	3.05		3.76	0.120		0.148
A1	2.08		2.41	0.082		0.095
A2	2.41	2.54	2.67	0.095	0.100	0.105
A3	0.64		1.09	0.025		0.043
b	0.41		0.51	0.016		0.020
b2	0.66		0.81	0.026		0.032
D	20.82		21.09	0.820		0.830
E	8.38	8.51	8.64	0.330	0.335	0.340
E1	7.49	7.62	7.75	0.295	0.300	0.305
E2	6.48		6.99	0.255		0.275
e	1.27	BSC.		0.050	BSC.	
ZD	0.95	REF.		0.037	REF.	

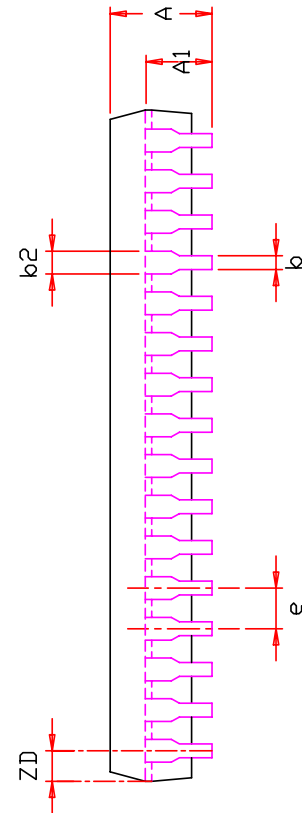

**NOTE :**

1. CONTROLLING DIMENSION : MM
2. DIMENSION D AND E1 DO NOT INCLUDE MOLD PROTRUSION.
3. DIMENSION b2 DOES NOT INCLUDE DAMBAR PROTRUSION/INTRUSION.

ISSI	TITLE	32L 300mil SOJ Package Outline	REV.	C	DATE	08/14/2009

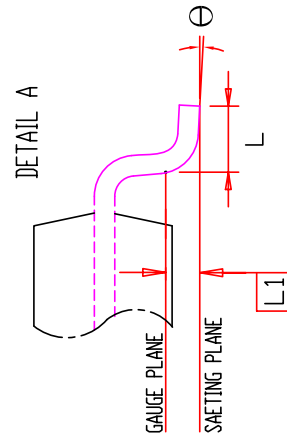
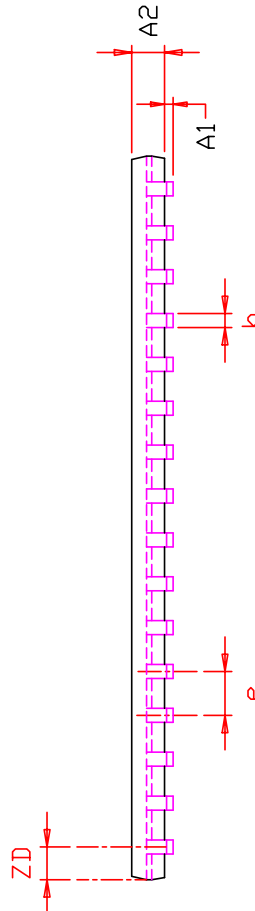
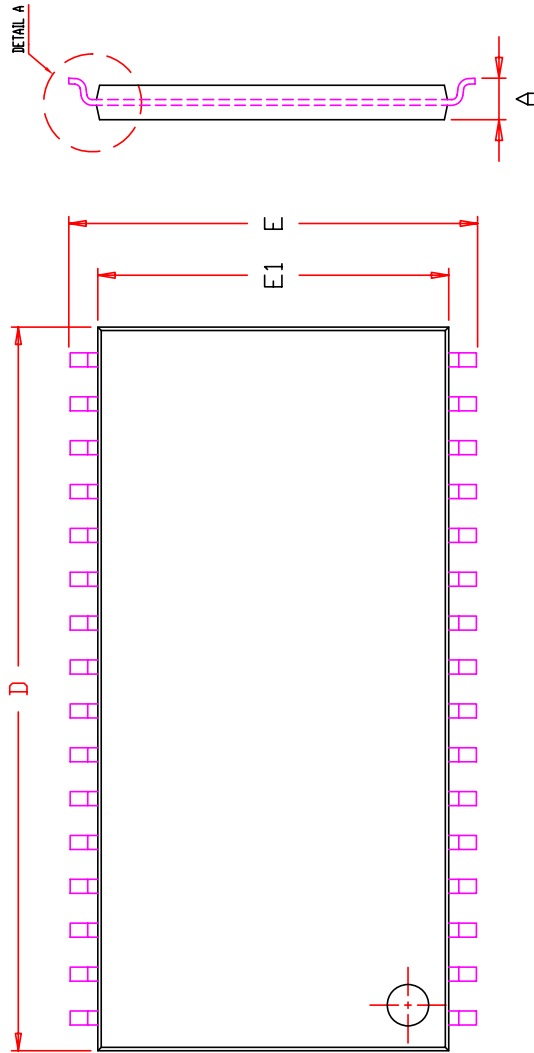

SYMBOL	DIMENSION IN MM		DIMENSION IN INCH	
	MIN.	NOM. MAX.	MIN.	NOM. MAX.
A	1.00	1.20	0.039	0.047
A1	0.05	0.15	0.002	0.006
A2	0.95	1.00	0.037	0.039
b	0.30	0.52	0.012	0.020
D	20.82	20.95	21.08	0.825
E	11.56	11.76	11.96	0.463
E1	10.03	10.16	10.29	0.400
e	1.27 BSC.		0.050 BSC.	
L	0.40	0.50	0.60	0.020
L1	0.25 BSC.		0.010 BSC.	
ZD	0.95 REF.		0.037 REF.	
θ	0	8°	0	8°

**NOTE :**

1. CONTROLLING DIMENSION : MM
2. DIMENSION D AND E1 DO NOT INCLUDE MOLD PROTRUSION.
3. DIMENSION b DOES NOT INCLUDE DAMBAR PROTRUSION/INTRUSION.



TITLE  
 32L 400mil TSOP-2  
 Package Outline

REV. **E**

DATE 06/23/2009

SYMBOL	DIMENSION IN MM		DIMENSION IN INCH	
	MIN.	MAX.	MIN.	MAX.
A		1.20		0.047
A1	0.20	0.30	0.008	0.012
$\phi b$	0.30	0.40	0.012	0.016
D	7.90	8.10	0.311	0.319
D1	5.25	BSC	0.207	BSC
E	5.90	6.10	0.232	0.240
E1	3.75	BSC	0.148	BSC
e	0.75	BSC,	0.030	BSC,
ZD	1.375	REF.	0.054	REF.
ZE	1.125	REF.	0.044	REF.

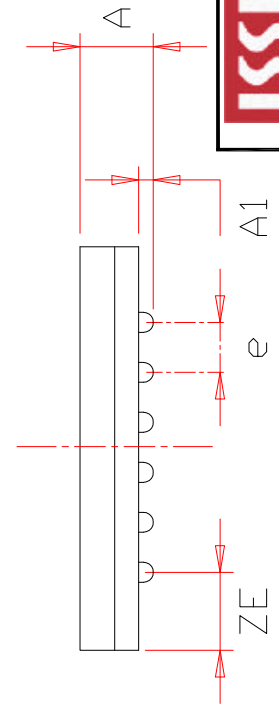
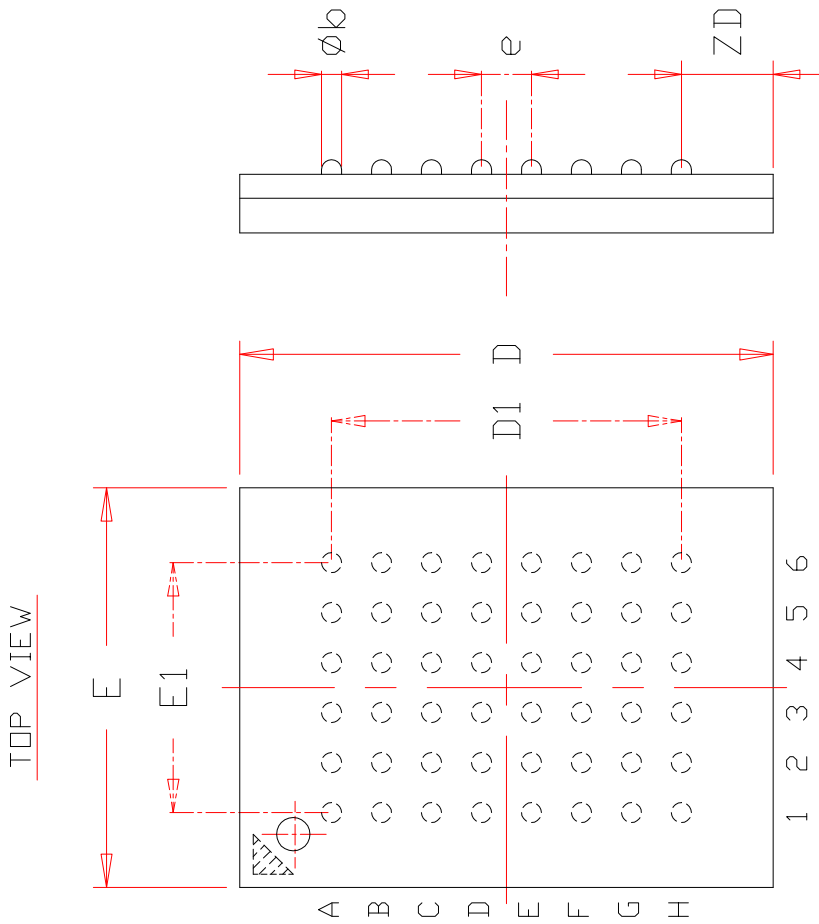

**NOTE :**

1. CONTROLLING DIMENSION : MM .
2. Reference document : JEDEC MO-207

	TITLE	48L 6x8mm TF-BGA Package Outline	REV.	C	DATE	08/12/2008
--	-------	----------------------------------	------	---	------	------------