

## PACKAGING INFORMATION

450-mil Plastic SOP  
 Package Code: Q (32-pin)

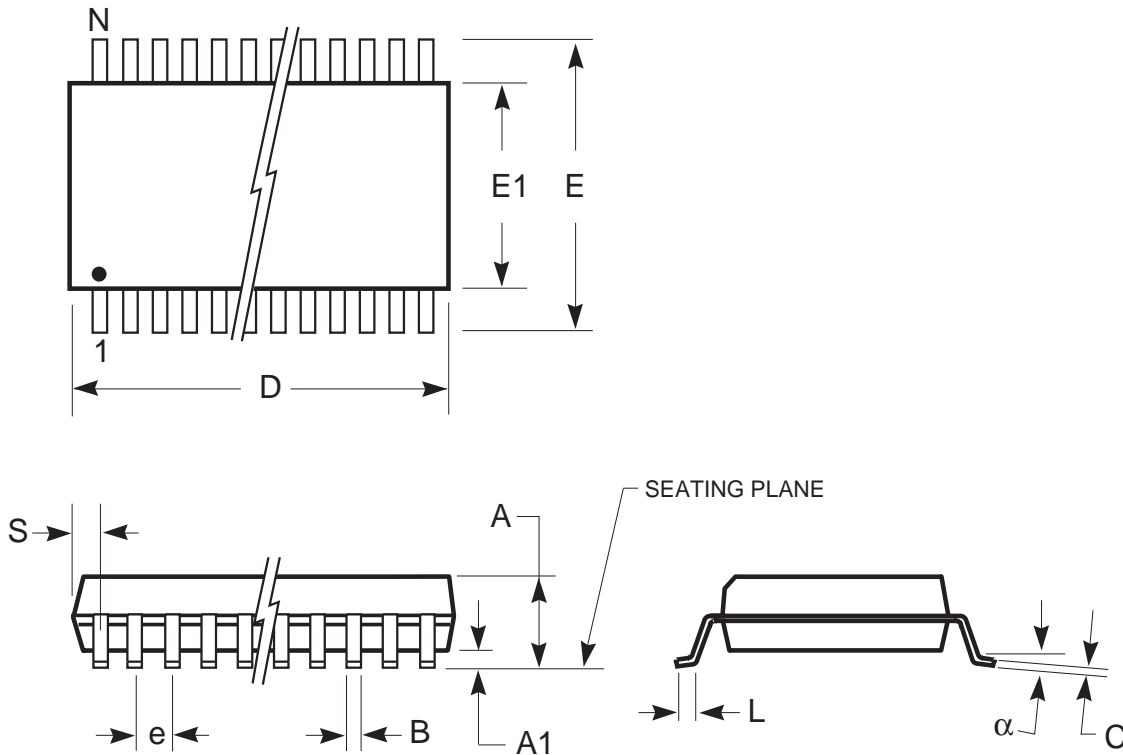

	MILLIMETERS		INCHES	
<b>Symbol</b>	<b>Min.</b>	<b>Max.</b>	<b>Min.</b>	<b>Max.</b>
No. Leads	<b>32</b>			
A	—	3.00	—	0.118
A1	0.10	—	0.004	—
B	0.36	0.51	0.014	0.020
C	0.15	0.30	0.006	0.012
D	20.14	20.75	0.793	0.817
E	13.87	14.38	0.546	0.566
E1	11.18	11.43	0.440	0.450
e	1.27 BSC		0.050 BSC	
L	0.58	0.99	0.023	0.039
$\alpha$	0°	10°	0°	10°
S	—	0.86	—	0.034

**Notes:**

1. Controlling dimension: inches, unless otherwise specified.
2. BSC = Basic lead spacing between centers.
3. Dimensions D and E1 do not include mold flash protrusions and should be measured from the bottom of the package.
4. Formed leads shall be planar with respect to one another within 0.004 inches at the seating plane.